

貴金属合金多接点ワイパ採用により、信頼性に優れるRJシリーズ

## 1回転型サーメットマ RJ-6 SINGLE TURN CERMET TRIMMERS

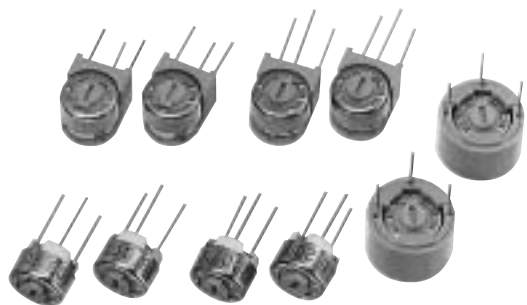

### ■特長 FEATURES

- 10 Ω ~ 5 MΩの幅広い抵抗値範囲
- 接触抵抗変化(C.R.V.)は1 %以下
- 貴金属合金多接点ワイパ採用
- Wide resistance range from 10 Ω to 5 MΩ
- Low contact resistance variation (1 % maximum)
- Precious metal alloy wiper

内部構造図 INTERNAL STRUCTURE

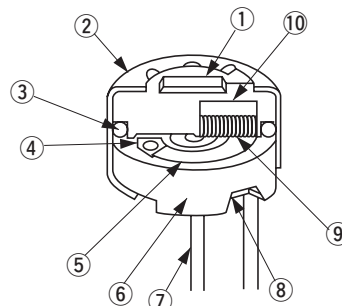

名称 Part name	材料 Material	燃焼性 Flammability
① ロータ Rotor	PBT (ポリブチレンテレフタレート) Polybutyleneterephthalate	UL-94HB
② カバー Cover	ステンレス Stainless steel	—
③ Oリング “O” ring	シリコンゴム Silicone rubber	UL-94HB
④ 電極体 Electrode	Ag-Pd サーメット Ag-Pd cermet	—
⑤ 抵抗体 Resistive element	RuO <sub>2</sub> サーメット RuO <sub>2</sub> cermet	
⑥ ベースエレメント Base element	セラミック Ceramic	—
⑦ 端子 Terminal pin	ニッケル、金めっき Nickel, Gold-plated	
⑧ 接着剤 Adhesive	エポキシ Epoxy	—
⑨ ワイパ(摺動子) Wiper	多元合金 Multi metal alloy	
⑩ ゴム板 Rubber cushion	シリコンゴム Silicone rubber	—

CFCs、ハロン、四塩化炭素および特定臭素系難燃剤 (PBBOs, PBBs) は使用しておりません。

CFCs, Halon, Carbon tetrachloride and designated bromic flame retardant PBBOs and PBBs are not used in our products.



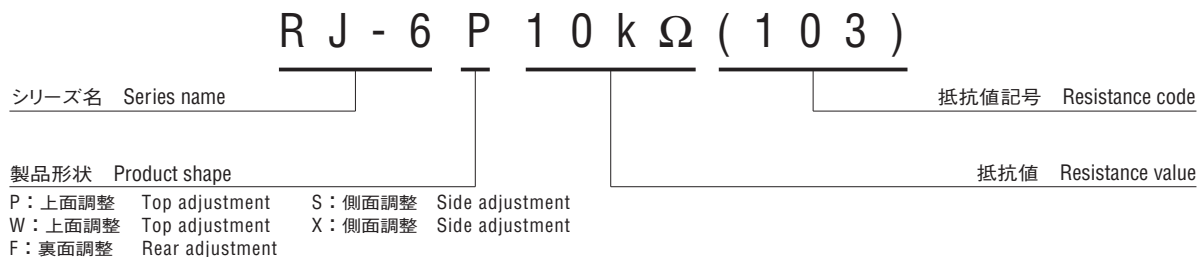



### ■型式表示 PART NUMBER DESIGNATION



※ご注文に際しては、型式一覧表をご確認ください。  
Please refer to the LIST OF PART NUMBERS when placing orders.

## RJ-6 CERMET TRIMMERS

### ■型式一覧表 LIST OF PART NUMBERS

調整方向 Adjustment position	端子形状 (上面図) Shape of terminal (Top view)	包装形態 Form of packaging ビニール袋 Vinyl bag	包装数量 Pieces in package
上面調整 Top adjustment 		RJ-6P	50 pcs./pack
		RJ-6W	
側面調整 (↑調整面) (↑ Adjustment direction)		RJ-6S	
		RJ-6X	
裏面調整 Rear adjustment		➡ RJ-6F	

### ■電気的特性 ELECTRICAL CHARACTERISTICS

公称抵抗値範囲 Nominal resistance range	10 Ω ~ 5 MΩ
公称抵抗値許容差 Nominal resistance tolerance	± 10 %
定格電力 Power ratings	0.5 W (70 °C) 0 W (120 °C)
抵抗変化特性 Resistance law	直線性 (B) Linear law
最大入力電圧 Maximum input voltage	DC200 V 又は定格電力の何れか小さい方 DC200 V or power rating, whichever is smaller
最大ワイパ電流 Maximum wiper current	100 mA 又は定格電力の何れか小さい方 100 mA or power rating, whichever is smaller
有効電気的回転角度 Effective electrical angle	230 ° (1 turn)
残留抵抗値 End resistance	1 % 又は 2 Ω の何れか大きい方以下 1 % or 2 Ω, whichever is greater
接触抵抗変化 C.R.V.	1 % 又は 3 Ω の何れか大きい方以下 1 % or 3 Ω, whichever is greater
使用温度範囲 Operating temp. range	-55 ~ 120 °C
抵抗温度係数 Temp. coefficient	10 Ω, 20Ω, 5 MΩ : ± 250 10 <sup>-6</sup> /°C maximum 50 Ω ~ 2 MΩ : ± 100 10 <sup>-6</sup> /°C maximum
絶縁抵抗 Insulation resistance	1000 MΩ minimum (DC500 V)
絶縁耐圧 Dielectric strength	AC900 V, 60 s
質量 Net weight	Approx. 0.60 g (RJ-6P,W) Approx. 0.80 g (RJ-6S, X) Approx. 1.01 g (RJ-6F)

### 〈公称抵抗値〉

#### <Nominal resistance values>

➡ 10 Ω	➡ 20 Ω	50 Ω	100 Ω	200 Ω	500 Ω	1 kΩ	2 kΩ	5 kΩ	10 kΩ
20 kΩ	➡ 25 kΩ	50 kΩ	100 kΩ	200 kΩ	➡ 250 kΩ	500 kΩ	1 MΩ	2 MΩ	➡ 5 MΩ

Fig. 1

※ ご注文に際しては、〈公称抵抗値〉(Fig. 1)について上記すべての組み合わせを用意しています。

※ ご注文に際しては、上記型式をご確認ください。

※ The above part numbers are all available with the respective combination of <Nominal resistance values> (Fig. 1).

※ Verify the above part numbers when placing orders.

➡印の型式、公称抵抗値は受注生産となります。

The products indicated by ➡ mark are manufactured upon receipt of order basis.

### ■機械的特性

#### MECHANICAL CHARACTERISTICS

機械的回転角度 Mechanical angle	270 ° (1 turn)
回転トルク Operating torque	2~ 15 mN·m (20 ~ 153 gf·cm)
回転止強度 Stop strength	50 mN·m (510 gf·cm) minimum
回転寿命 Rotational life	200 cycles 10 Ω ~ 200 Ω [ ΔR/R ≤ ± (0.5 Ω + 3 %) ] 500 Ω ~ 5 MΩ [ ΔR/R ≤ ± (0.5 Ω + 2 %) ]
端子強度 Terminal to strength	10 N {1.02 kgf} minimum (引張り強さ Tensile strength)
操作部の押し強さ Thrust rotor	10 N {1.02 kgf} minimum
はんだ付け性 Solderability	245 ± 3 °C, 2 ~ 3 s

{ } : 参考値 Reference only

### ■環境特性

#### ENVIRONMENTAL CHARACTERISTICS

試験項目 Test item	試験条件 Test conditions	仕様 Specifications
熱衝撃 Thermal shock	-65 ~ 125 °C (0.5 h), 5 cycles	[ ΔR/R ≤ 1 % ] [ S.S. ≤ 1 % ]
耐湿性 Humidity	-10 ~ 65 °C (相対湿度 80 ~ 98 %), 10 cycles, 240 h	[ ΔR/R ≤ 1 % ]
耐衝撃性 Shock	981 m/s <sup>2</sup> , 6 ms 6 directions for 3 times each	[ ΔR/R ≤ 1 % ] [ S.S. ≤ 1 % ]
耐振動性 Vibration	振幅 (Amplitude) 1.52 mm or 加速度 (Acceleration) 196 m/s <sup>2</sup> , 10 ~ 2000 Hz, 3 directions, 12 times each	[ ΔR/R ≤ 1 % ] [ S.S. ≤ 1 % ]
負荷寿命 Load life	70 °C, 0.5 W, 1000 h	[ ΔR/R ≤ 2 % ] [ S.S. ≤ 1 % ]
低温動作 Low temp. operation	-55 °C, 2 h	[ ΔR/R ≤ 1 % ] [ S.S. ≤ 2 % ]
高温放置 High temp. exposure	120 °C, 250 h	[ ΔR/R ≤ 2 % ] [ S.S. ≤ 2 % ]
耐水、密閉性 Immersion seal	85 °C, 60 s	もれ無し (連続気泡無し) No leaks (No continuous bubbles)
はんだ耐熱性 Soldering heat	フロー Flow soldering : 260 ± 3 °C, 5 ~ 6 s, twice こてによるはんだ付け Manual soldering : 380 ± 10 °C, 3 ~ 4 s	[ ΔR/R ≤ 1 % ]

ΔR/R : 全抵抗値変化 Change in total resistance

S 使用に際しては設計規定値等の取扱いをお願いします。

■仕様は改善のために変更されることがありますので、ご注文の際は仕様をご確認ください。当カタログは参考仕様ですので、S 使用に際しては設計規定値等の取扱いをお願いします。  
Specifications are subject to change without notice. Specifications in this catalog are for reference. The formal specification sheets will be submitted upon request.

### ■最大入力定格 MAXIMUM INPUT RATINGS

公称抵抗値 Nominal resistance values (Ω)	抵抗値記号 Resistance code	最大入力電圧 Maximum input voltage (V)	最大ワイバ電流 Maximum wiper current (mA)
➡ 10 ➡ 20 50 100 200 500	100 200 500 101 201 501	1.00 2.00 5.00 7.07 10.0 15.8	100 100 100 70.7 50.0 31.6
1 k 2 k 5 k 10 k 20 k ➡ 25 k 50 k	102 202 502 103 203 253 503	22.4 31.6 50.0 70.7 100 112 158	22.4 15.8 10.0 7.07 5.00 4.48 3.16
100 k 200 k ➡ 250 k 500 k 1 M 2 M ➡ 5 M	104 204 254 504 105 205 505	200 200 200 200 200 200 200	2.00 1.00 0.80 0.40 0.20 0.10 0.04

➡印の公称抵抗値は受注生産となります。  
The products indicated by ➡ mark are manufactured upon receipt of order basis.

### ■外形寸法図 OUTLINE DIMENSIONS

Unless otherwise specified, tolerance: ± 0.3 (Unit: mm)

#### ● RJ-6P 上面調整 Top adjustment

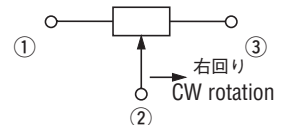
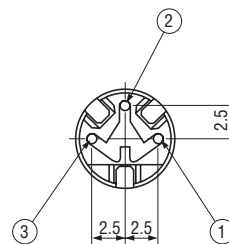
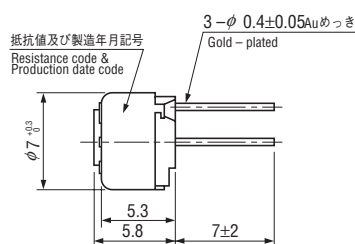
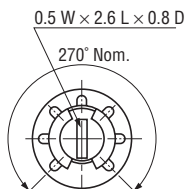

#### ● RJ-6W 上面調整 Top adjustment

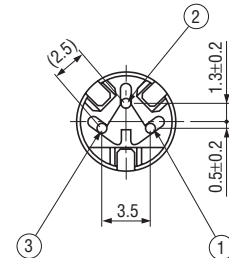
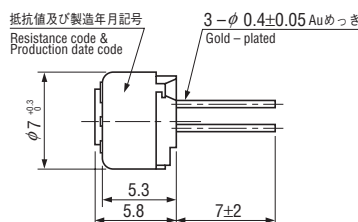
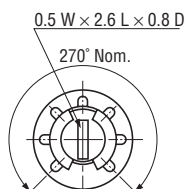

★P型とピンピッチが異なります。  
Pin pitch in W type is different from P type.

#### ● RJ-6S 側面調整 Side adjustment

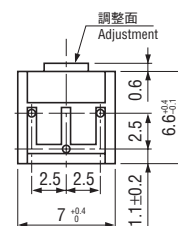
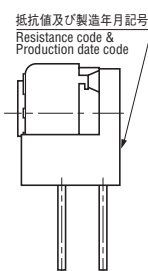
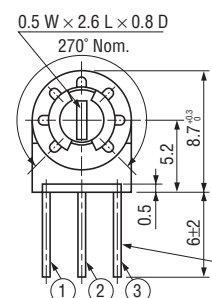

仕様は改善のために変更されることがありますので、ご注文の際は仕様をご確認ください。当カタログは参考仕様ですので、ご使用に際しては納入仕様書等の取り交わしをお願い致します。  
Specifications are subject to change without notice. Specifications in this catalog are for reference. The formal specification sheets will be submitted upon request.

## RJ-6 CERMET TRIMMERS

### ■外形寸法図 OUTLINE DIMENSIONS

Unless otherwise specified, tolerance:  $\pm 0.3$  (Unit: mm)

#### ● RJ-6X 側面調整 Side adjustment

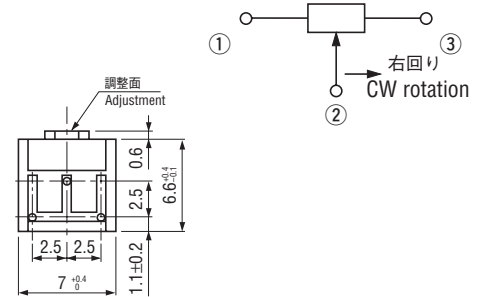
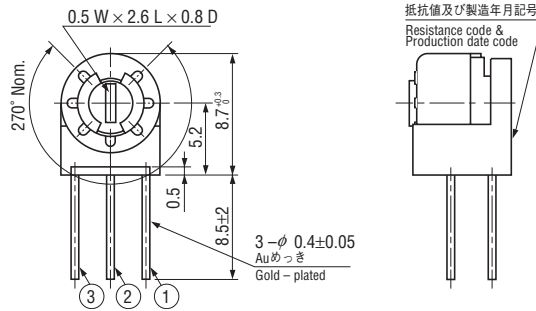

★S型とピン位置及びストップ位置が異なります。  
Pin position & stopper position of X type are different from S type.

#### ● RJ-6F 裏面調整 Rear adjustment

<受注生産品 Semi-standard products>

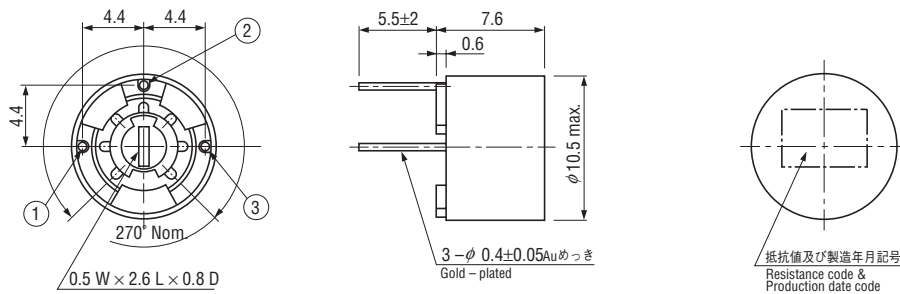

### ■包装仕様

#### <ビニール袋の包装仕様>

- ビニール袋での包装は、50個/袋となります。
- ビニール袋の箱詰めは、200個 (RJ-6Fは100個) を製品箱に包装致します。

### ■PACKAGING SPECIFICATIONS

#### <Vinyl bag packaging specifications>

- Unit of bulk in vinyl bag packaging is 50 pcs. per pack.
- Boxing of bulk in vinyl bags is performed with 200 pcs. (RJ-6F is 100 pcs.) per box.