

512K (64K x 8-bit) UV and OTP EPROM

DESCRIPTION

The Hitachi HN27512 is a 512-Kilobit Ultraviolet Erasable and One-Time Programmable Electrically Programmable Read Only Memory organized as 65,536 x 8-bits.

The HN27512 features low power dissipation and high speed programming.

Hitachi's HN27512 is offered in JEDEC-Standard Byte-Wide EPROM pinouts in a 28-pin Ceramic and Plastic DIP packages.

FEATURES

- Fast Access Times:
250 ns/300 ns (max)
- Single Power Supply:
 $V_{CC} = 5 V \pm 10\%$
- Low Power Dissipation:
Active Mode: 45 mA (typ)
Standby Mode: 40 mA (max)
- High Speed Programming
- Programming Power Supply:
 $V_{PP} = 12.5 V \pm 0.3 V$
- Pin Arrangement:
JEDEC Standard Byte-Wide EPROM
- Package:
28-pin Ceramic DIP
28-pin Plastic DIP

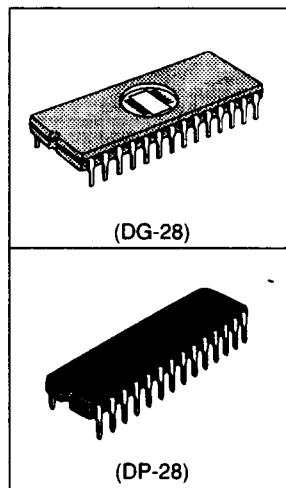

ORDERING INFORMATION

Type No.	Access Time	Package
HN27512G-25	250 ns	28-pin Ceramic DIP
HN27512G-30	300 ns	(DG-28)
HN27512P-25	250 ns	28-pin Plastic DIP
HN27512P-30	300 ns	(DP-28)

PIN DESCRIPTION

Pin Name	Function
$A_0 - A_{15}$	Address
$I/O_0 - I/O_7$	Input/Output
\overline{CE}	Chip Enable
\overline{OE}	Output Enable
V_{CC}	Power Supply
V_{PP}	Programming Supply
V_{SS}	Ground

PIN ARRANGEMENT

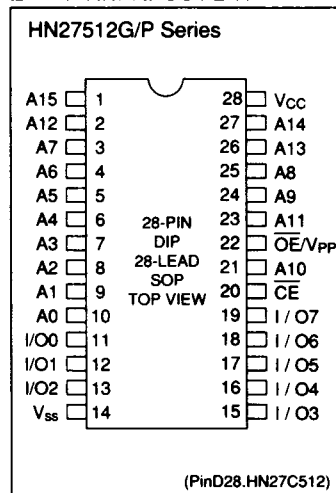

■ BLOCK DIAGRAM

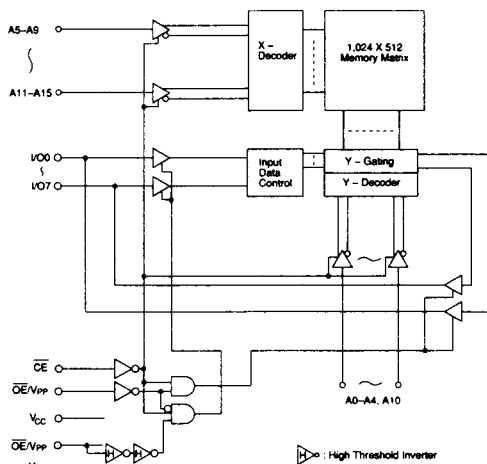

(BD.HN27512)

■ MODE SELECTION

Mode	V_{CC}	\overline{OE}	\overline{OE}/V_{PP}	A_9	I/O
Read	V_{CC}	V_{IL}	V_{IL}	X ¹	D_{OUT}
Output Disable	V_{CC}	V_{IL}	V_{IH}	X	High-Z
Standby	V_{CC}	V_{IH}	X	X	High-Z
Program	V_{CC}	V_{IL}	V_{PP}	X	D_{IN}
Program Verify	V_{CC}	V_{IL}	V_{IL}	X	D_{OUT}
Program Inhibit	V_{CC}	V_{IH}	V_{PP}	X	High-Z
Identifier	V_{CC}	V_{IL}	V_{IL}	V_H ²	ID

- Notes: 1. X = Don't Care.
 2. $11.5\text{ V} \leq V_H \leq 12.5\text{ V}$

■ ABSOLUTE MAXIMUM RATINGS

Item	Symbol	Value	Unit
Supply Voltage ¹	V_{CC}	-0.6 to +7.0	V
Programming Voltage ¹	V_{PP}	-0.6 to +13.5	V
All Input and Output Voltage ¹	V_{IN}, V_{OUT}	-0.6 to +7.0	V
A_9 Input Voltage	V_{ID}	-0.6 to +13.5	V
Operating Temperature Range	T_{OPR}	0 to +70	°C
Storage Temperature Range	T_{STG}	-65 to +125 ² -55 to +125 ³	°C
Storage Temperature Under Bias	T_{BIAS}	-10 to +80	°C

- Notes: 1. Relative to V_{SS} .
 2. HN27512G.
 3. HN27512P.

HITACHI

■ CAPACITANCE ($T_a = 25^\circ\text{C}$, $f = 1\text{MHz}$)

Item	Symbol	Typ.	Max.	Unit	Test Condition
Input Capacitance	C_{IN}	4	6	pF	$V_{IN} = 0\text{V}$, all pins except \overline{OE}/V_{PP}
Output Capacitance	C_{OUT}	8	12	pF	$V_{OUT} = 0\text{V}$

■ DC ELECTRICAL CHARACTERISTICS FOR READ OPERATION

($V_{CC} = 5\text{V} \pm 10\%$, $T_a = 0$ to 70°C)

Item	Symbol	Min.	Typ.	Max.	Unit	Test Condition
Input Leakage Current	I_{LI}	-	-	10	μA	$V_{IN} = 0\text{V}$ to V_{CC}
Output Leakage Current	I_{LO}	-	-	10	μA	$V_{OUT} = 0\text{V}$ to V_{CC}
Operating V_{CC} Current	I_{CC}	-	45	100	mA	$\overline{CE} = \overline{OE} = V_{IL}$
Standby V_{CC} Current	I_{SB}	-	-	40	mA	$\overline{CE} = V_{IH}$
Input Voltage	V_{IH}	2.2	-	$V_{CC} + 1^2$	V	
	V_{IL}	-0.1 ¹	-	0.8	V	
Output Voltage	V_{OH}	2.4	-	-	V	$I_{OH} = 1.0\text{mA}$
	V_{OL}	-	-	0.45	V	$I_{OL} = 2.1\text{mA}$

- Notes: 1. V_{IL} min = -0.6 V for pulse width $\leq 20\text{ns}$.
 2. V_{IH} max = $V_{CC} + 1.5\text{V}$ for pulse width $\leq 20\text{ns}$.
 If V_{IH} is over the specified maximum value, Read operation can not be guaranteed.

■ AC ELECTRICAL CHARACTERISTICS FOR READ OPERATION

($V_{CC} = 5\text{V} \pm 10\%$, $T_a = 0$ to 70°C)

Test Conditions

- Input pulse levels: 0.45 V / 2.4 V
- Input rise and fall times: $\leq 20\text{ns}$
- Output load: 1 TTL Gate + 100 pF (Including scope and jig)
- Reference levels for measuring timing: 0.8 V / 2.0 V

Item	Symbol	-25		-30		Unit	Test Condition
		Min.	Max.	Min.	Max.		
Address Access Time	t_{ACC}	-	250	-	300	ns	$\overline{CE} = \overline{OE} = V_{IL}$
Chip Enable Access Time	t_{CE}	-	250	-	300	ns	$\overline{OE} = V_{IL}$
Output Enable Access Time	t_{OE}	-	100	-	120	ns	$\overline{CE} = V_{IL}$
Output Disable to High-Z ¹	t_{DF}	0	60	0	105	ns	$\overline{CE} = V_{IL}$
Output Hold to Address Change	t_{OH}	0	-	0	-	ns	$\overline{CE} = \overline{OE} = V_{IL}$

- Note: 1. t_{DF} is defined as the time at which the output becomes an open circuit and data is no longer driven.



■ READ TIMING WAVEFORM

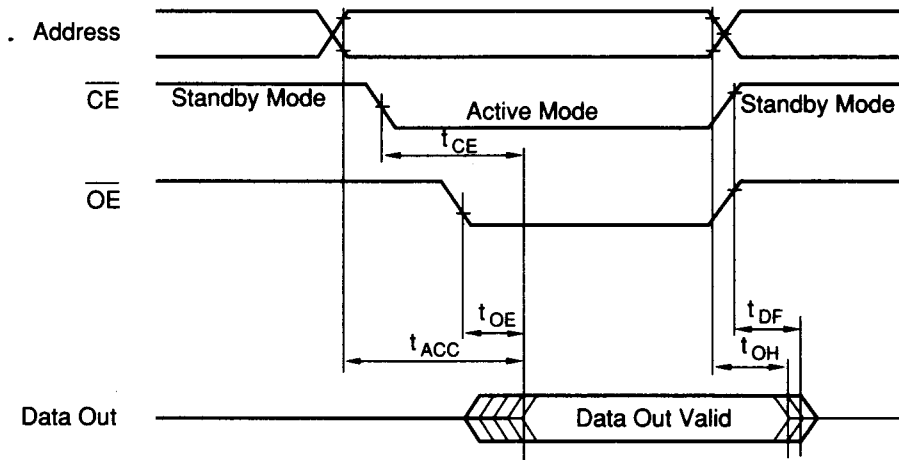

(TD.R.HN27512)

■ DC ELECTRICAL CHARACTERISTICS FOR PROGRAMMING OPERATIONS

($V_{CC} = 6.0\text{ V} \pm 0.25\text{ V}$, $V_{PP} = 12.5\text{ V} \pm 0.3\text{ V}$, $T_a = 25\text{ }^\circ\text{C} \pm 5\text{ }^\circ\text{C}$)

Item	Symbol	Min.	Typ.	Max.	Unit	Test Condition
Input Leakage Current	I_{LI}	-	-	10	μA	$V_{IN} = 5.25\text{ V}$
Operating V_{CC} Current	I_{CC}	-	-	100	mA	
Operating V_{PP} Current	I_{PP}	-	35	50	mA	$\overline{CE} = V_{IL}$
Input Voltage ¹	V_{IH}	2.0	-	$V_{CC} + .5$ ²	V	
	V_{IL}	-0.1 ¹	-	0.8	V	
Output Voltage	V_{OH}	2.4	-	-	V	$I_{OH} = -400\text{ }\mu\text{A}$
	V_{OL}	-	-	0.45	V	$I_{OH} = 2.1\text{ mA}$

- Notes: 1. V_{IL} min = -0.6 V for pulse width $\leq 20\text{ ns}$.
 2. If V_{IH} is over the specified maximum value, programming operation can not be guaranteed.

■ AC ELECTRICAL CHARACTERISTICS FOR PROGRAMMING OPERATIONS

($V_{CC} = 6\text{ V} \pm 0.25\text{ V}$, $V_{PP} = 12.5\text{ V} \pm 0.5\text{ V}$, $T_a = 25^\circ\text{C} \pm 5^\circ\text{C}$)

Test Conditions

- Input pulse levels: 0.45 V / 2.4 V
- Input rise and fall times: $\leq 20\text{ ns}$
- Reference levels for measuring timing: 0.8 V / 2.0V

Item	Symbol	Min.	Typ.	Max.	Unit	Test Condition
Address Setup Time	t_{AS}	2	-	-	μs	
Address Hold Time	t_{AH}	0	-	-	μs	
Data Setup Time	t_{DS}	2	-	-	μs	
V_{PP} Setup Time	t_{VPS}	2	-	-	μs	
V_{CC} Setup Time	t_{VCS}	2	-	-	μs	
Output Enable Hold Time	t_{OEh}	2	-	-	μs	
Output Disable Time	t_{DF}	0	-	130	ns	
\overline{CE} Initial Programming Pulse Width	t_{PW}	0.95	1.0	1.05	ms	
\overline{CE} Overprogramming Pulse Width	t_{OPW}	2.85	-	78.75	ms	
Data Hold Time	t_{DH}	2	-	-	μs	
V_{PP} Recovery Time	t_{VR}	2	-	-	μs	
Data Valid from Chip Enable	t_{DV}	-	-	1	μs	

Note: 1. t_{DF} is defined as the time at which the output becomes an open circuit and data is no longer driven.

■ HIGH PERFORMANCE PROGRAMMING FLOWCHART

The Hitachi HN27512 can be programmed with the High Performance Programming algorithm shown in the following flowchart. This algorithm provides a fast programming time without voltage stress to the device or deterioration in reliability of programmed data.

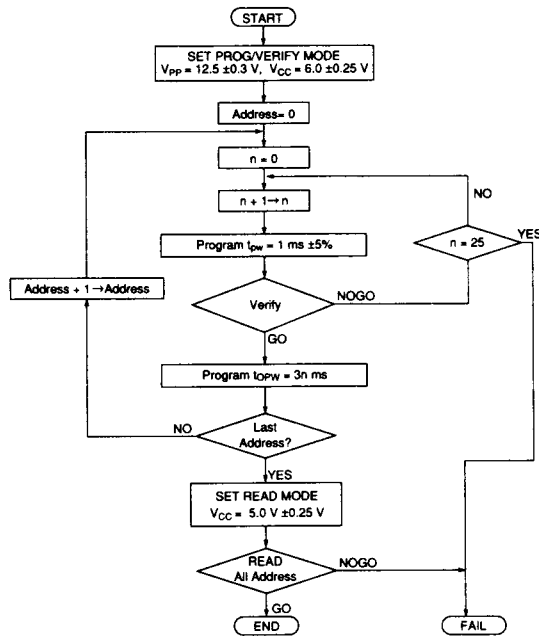

(FC.P.HN27512)

■ HIGH PERFORMANCE PROGRAMMING TIMING WAVEFORM

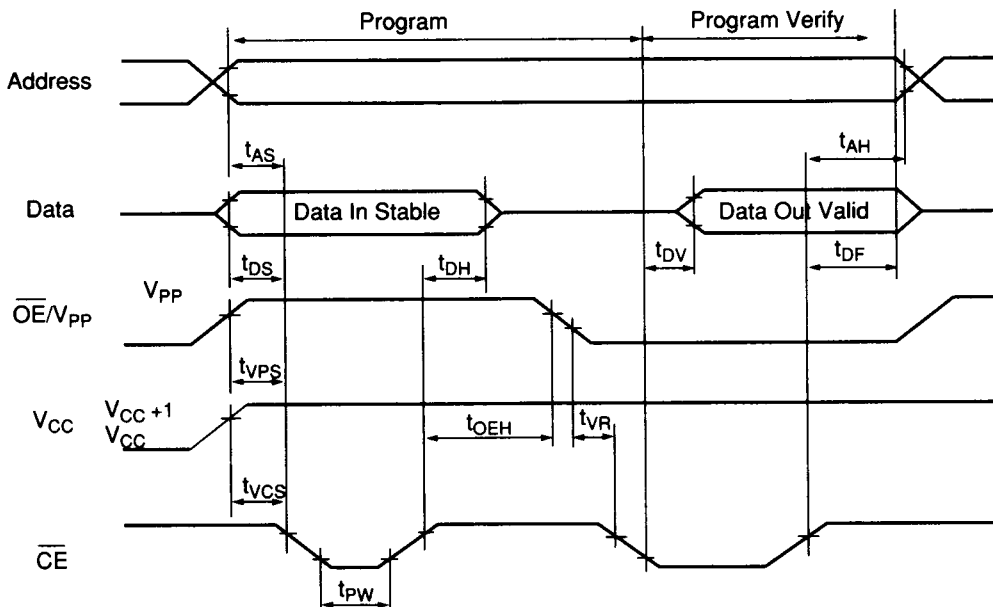

(TD.PP.HN27512)

HITACHI

■ ERASING THE HN27512

The Hitachi HN27512 Ceramic DIP package allows the device to be erased by exposure to ultraviolet light of 2537Å. All of the data is changed to "1" after this erasure procedure. The minimum integrated dose (UV intensity x exposure time) for erasure is 15 W-sec/cm².

■ DEVICE IDENTIFIER MODE DESCRIPTION

The Device Identifier Mode allows binary codes to be read from the outputs that identify the manufacturer and the type of device. Using this mode with programming equipment, the device will automatically match its own erase and programming algorithm.

■ HN27512 SERIES IDENTIFIER CODE

Identifier	A ₀	I/O ₇	I/O ₆	I/O ₅	I/O ₄	I/O ₃	I/O ₂	I/O ₁	I/O ₀	Hex Data
Manufacturer Code	V _{IL}	0	0	0	0	0	1	1	1	07
Device Code	V _{IH}	1	0	0	1	0	1	0	0	94

- Notes: 1. A₀ = 12.0 V ± 0.5V
 3. A₁-A₈, A₁₀-A₁₅, CE, OE/V_{pp} = V_{IL}

■ HN27512P RECOMMENDED SCREENING CONDITIONS

Before mounting the HN27512P package, please make the following screening (baking without bias) shown below:

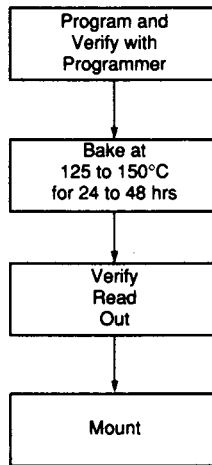

(RSC.EPROM)

