

# OPA177

## Precision OPERATIONAL AMPLIFIER

### FEATURES

- LOW OFFSET VOLTAGE: 25 $\mu$ V max
- LOW DRIFT: 0.3 $\mu$ V/ $^{\circ}$ C
- HIGH OPEN-LOOP GAIN: 130dB min
- LOW QUIESCENT CURRENT: 1.5mA typ
- REPLACES INDUSTRY-STANDARD OP AMPS: OP-07, OP-77, OP-177, AD707, ETC.

### APPLICATIONS

- PRECISION INSTRUMENTATION
- DATA ACQUISITION
- TEST EQUIPMENT
- BRIDGE AMPLIFIER
- THERMOCOUPLE AMPLIFIER

### DESCRIPTION

The OPA177 precision bipolar op amp feature very low offset voltage and drift. Laser-trimmed offset, drift and input bias current virtually eliminate the need for costly external trimming. The high performance and low cost make them ideally suited to a wide range of precision instrumentation.

The low quiescent current of the OPA177 dramatically reduce warm-up drift and errors due to thermo-

electric effects in input interconnections. It provides an effective alternative to chopper-stabilized amplifiers. The low noise of the OPA177 maintains accuracy.

OPA177 performance gradeouts are available. Packaging options include 8-pin plastic DIP and SO-8 surface-mount packages.

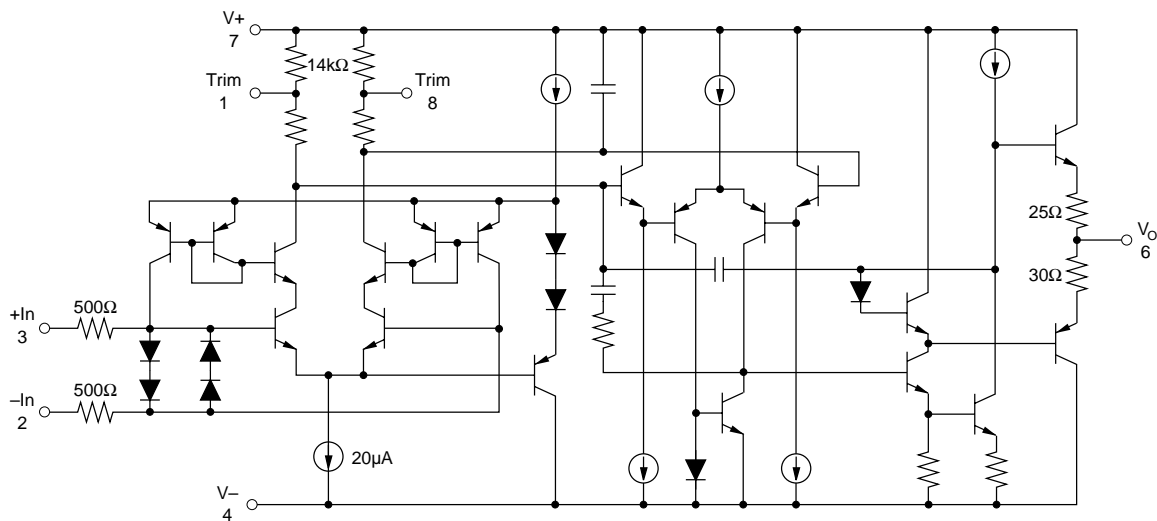

International Airport Industrial Park • Mailing Address: PO Box 11400, Tucson, AZ 85734 • Street Address: 6730 S. Tucson Blvd., Tucson, AZ 85706 • Tel: (520) 746-1111 • Twx: 910-952-1111  
Internet: <http://www.burr-brown.com/> • FAXLine: (800) 548-6133 (US/Canada Only) • Cable: BBRCORP • Telex: 066-6491 • FAX: (520) 889-1510 • Immediate Product Info: (800) 548-6132

# OPA177 SPECIFICATIONS

At  $V_S = \pm 15V$ ,  $T_A = +25^\circ C$ , unless otherwise noted.

| PARAMETER  | CONDITION  | OPA177F                              |  |                | OPA177G     |             |                  | UNITS                             |
|--|--|--------------------------------------|--|----------------|-------------|-------------|------------------|-----------------------------------|
|  |  | MIN                                  | TYP                                      | MAX            | MIN         | TYP         | MAX              |                                   |
| <b>OFFSET VOLTAGE</b><br>Input Offset Voltage<br>Long-Term Input Offset <sup>(1)</sup><br>Voltage Stability<br>Offset Adjustment Range<br>Power Supply Rejection Ratio | $R_P = 20k\Omega$<br>$V_S = \pm 3V$ to $\pm 18V$                                   |                                      | 10<br>0.3                                | 25             |             | 20<br>0.4   | 60               | $\mu V$<br>$\mu V/Mo$<br>mV<br>dB |
| <b>INPUT BIAS CURRENT</b><br>Input Offset Current<br>Input Bias Current  |  |                                      | 0.3<br>0.5                               | 1.5<br>$\pm 2$ |             | *<br>*      | 2.8<br>$\pm 2.8$ | nA<br>nA                          |
| <b>NOISE</b><br>Input Noise Voltage<br>Input Noise Current   | 1Hz to 100Hz <sup>(2)</sup><br>1Hz to 100Hz  |                                      | 85<br>4.5                                | 150            |             | *<br>*      | *<br>*           | nVrms<br>pArms                    |
| <b>INPUT IMPEDANCE</b><br>Input Resistance   | Differential Mode <sup>(3)</sup><br>Common-Mode                                    | 26                                   | 45<br>200                                |                | 18.5        | *<br>*      |                  | M $\Omega$<br>G $\Omega$          |
| <b>INPUT VOLTAGE RANGE</b><br>Common-Mode Input Range <sup>(4)</sup><br>Common-Mode Rejection  | $V_{CM} = \pm 13V$   | $\pm 13$<br>130                      | $\pm 14$<br>140                          |                | *<br>115    | *<br>*      |                  | V<br>dB                           |
| <b>OPEN-LOOP GAIN</b><br>Large Signal Voltage Gain   | $R_L \geq 2k\Omega$<br>$V_O = \pm 10V$ <sup>(5)</sup>                              | 5110                                 | 12,000                                   |                | 2000        | 6000        |                  | V/mV                              |
| <b>OUTPUT</b><br>Output Voltage Swing<br><br>Open-Loop Output Resistance   | $R_L \geq 10k\Omega$<br>$R_L \geq 2k\Omega$<br>$R_L \geq 1k\Omega$                 | $\pm 13.5$<br>$\pm 12.5$<br>$\pm 12$ | $\pm 14$<br>$\pm 13$<br>$\pm 12.5$<br>60 |                | *<br>*<br>* | *<br>*<br>* |                  | V<br>V<br>V<br>$\Omega$           |
| <b>FREQUENCY RESPONSE</b><br>Slew Rate<br>Closed-Loop Bandwidth  | $R_L \geq 2k\Omega$<br>$G = +1$  | 0.1<br>0.4                           | 0.3<br>0.6                               |                | *<br>*      | *<br>*      |                  | V/ $\mu s$<br>MHz                 |
| <b>POWER SUPPLY</b><br>Power Consumption<br><br>Supply Current   | $V_S = \pm 15V$ , No Load<br>$V_S = \pm 3V$ , No Load<br>$V_S = \pm 15V$ , No Load |                                      | 40<br>3.5<br>1.3                         | 60<br>4.5<br>2 |             | *<br>*<br>* | *<br>*<br>*      | mW<br>mW<br>mA                    |

At  $V_S = \pm 15V$ ,  $-40^\circ C \leq T_A \leq +85^\circ C$ , unless otherwise noted.

|   |  |                 |                   |           |          |           |            |  |
|---|--|-----------------|-------------------|-----------|----------|-----------|------------|--|
| <b>OFFSET VOLTAGE</b><br>Input Offset Voltage<br>Average Input Offset<br>Voltage Drift<br>Power Supply Rejection Ratio  | $V_S = \pm 3V$ to $\pm 18V$                            |                 | 15<br>0.1         | 40<br>0.3 |          | 20<br>0.7 | 100<br>1.2 | $\mu V$<br>$\mu V/^\circ C$<br>dB            |
| <b>INPUT BIAS CURRENT</b><br>Input Offset Current<br>Average Input Offset Current<br>Drift <sup>(6)</sup><br>Input Bias Current<br>Average Input Bias Current<br>Drift <sup>(6)</sup> |  |                 | 0.5<br>1.5        | 2.2<br>40 |          | *<br>*    | 4.5<br>85  | nA<br>pA/ $^\circ C$<br>nA<br>pA/ $^\circ C$ |
| <b>INPUT VOLTAGE RANGE</b><br>Common-Mode Input Range<br>Common-Mode Rejection  | $V_{CM} = \pm 13V$                                     | $\pm 13$<br>120 | $\pm 13.5$<br>140 |           | *<br>110 | *<br>*    |            | V<br>dB                                      |
| <b>OPEN-LOOP GAIN</b><br>Large Signal Voltage Gain  | $R_L \geq 2k\Omega$ , $V_O = \pm 10V$                  | 2000            | 6000              |           | 1000     | 4000      |            | V/mV   |
| <b>OUTPUT</b><br>Output Voltage Swing   | $R_L \geq 2k\Omega$                                    | $\pm 12$        | $\pm 13$          |           | *<br>*   | *<br>*    |            | V  |
| <b>POWER SUPPLY</b><br>Power Consumption<br>Supply Current  | $V_S = \pm 15V$ , No Load<br>$V_S = \pm 15V$ , No Load |                 | 60<br>2           | 75<br>25  |          | *<br>*    | *<br>*     | mW<br>mA                                     |

\* Same as specification for product to left.

NOTES: (1) Long-Term Input Offset Voltage Stability refers to the averaged trend line of  $V_{OS}$  vs time over extended periods after the first 30 days of operation. Excluding the initial hour of operation, changes in  $V_{OS}$  during the first 30 operating days are typically less than  $2\mu V$ . (2) Sample tested. (3) Guaranteed by design. (4) Guaranteed by CMRR test condition. (5) To insure high open-loop gain throughout the  $\pm 10V$  output range,  $A_{OL}$  is tested at  $-10V \leq V_O \leq 0V$ ,  $0V \leq V_O \leq +10V$ , and  $-10V \leq V_O \leq +10V$ . (6) Guaranteed by end-point limits.

## PIN CONFIGURATION

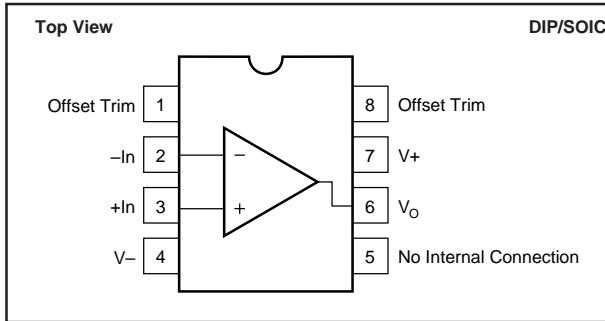

## ABSOLUTE MAXIMUM RATINGS

|  |                 |
|--|-----------------|
| Power Supply Voltage .....                         | ±22V            |
| Differential Input Voltage .....                   | ±30V            |
| Input Voltage .....                                | ±V <sub>S</sub> |
| Output Short Circuit .....                         | Continuous      |
| Operating Temperature:                             |                 |
| Plastic DIP (P), SO-8 (S) .....                    | -40°C to +85°C  |
| θ <sub>JA</sub> (PDIP) .....                       | 100°C/W         |
| θ <sub>JA</sub> (SOIC) .....                       | 160°C/W         |
| Storage Temperature:                               |                 |
| Plastic DIP (P), SO-8 (S) .....                    | -65°C to +125°C |
| Junction Temperature .....                         | +150°C          |
| Lead Temperature (soldering, 10s) P packages ..... | +300°C          |
| (soldering, 3s) S package .....                    | +260°C          |

## PACKAGE/ORDERING INFORMATION

| PRODUCT  | PACKAGE            | PACKAGE DRAWING NUMBER <sup>(1)</sup> | TEMPERATURE RANGE |
|----------|--------------------|---------------------------------------|-------------------|
| OPA177FP | 8-Pin Plastic DIP  | 006                                   | -40°C to +85°C    |
| OPA177GP | 8-Pin Plastic DIP  | 006                                   | -40°C to +85°C    |
| OPA177GS | SO-8 Surface-Mount | 182                                   | -40°C to +85°C    |

NOTE: (1) For detailed drawing and dimension table, please see end of data sheet, or Appendix C of Burr-Brown IC Data Book.

## ELECTROSTATIC DISCHARGE SENSITIVITY

Any integrated circuit can be damaged by ESD. Burr-Brown recommends that all integrated circuits be handled with appropriate precautions. ESD can cause damage ranging from subtle performance degradation to complete device failure. Precision integrated circuits may be more susceptible to damage because very small parametric changes could cause the device not to meet published specifications.

Burr-Brown's standard ESD test method consists of five 1000V positive and negative discharges (100pF in series with 1.5kΩ) applied to each pin.

Failure to observe proper handling procedures could result in small changes to the OPA177's input bias current.

The information provided herein is believed to be reliable; however, BURR-BROWN assumes no responsibility for inaccuracies or omissions. BURR-BROWN assumes no responsibility for the use of this information, and all use of such information shall be entirely at the user's own risk. Prices and specifications are subject to change without notice. No patent rights or licenses to any of the circuits described herein are implied or granted to any third party. BURR-BROWN does not authorize or warrant any BURR-BROWN product for use in life support devices and/or systems.

# TYPICAL PERFORMANCE CURVES

At  $T_A = +25^\circ\text{C}$ ,  $V_S = \pm 15\text{V}$ , unless otherwise noted.

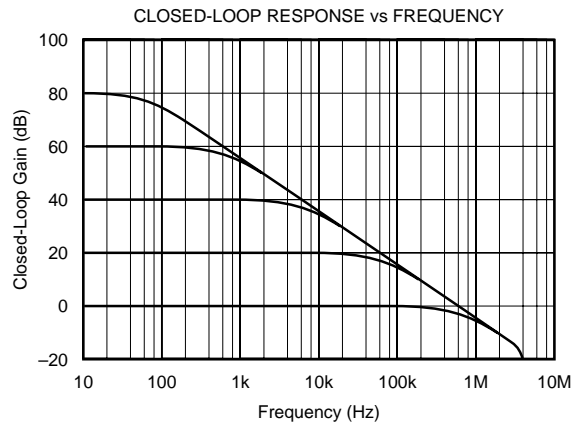
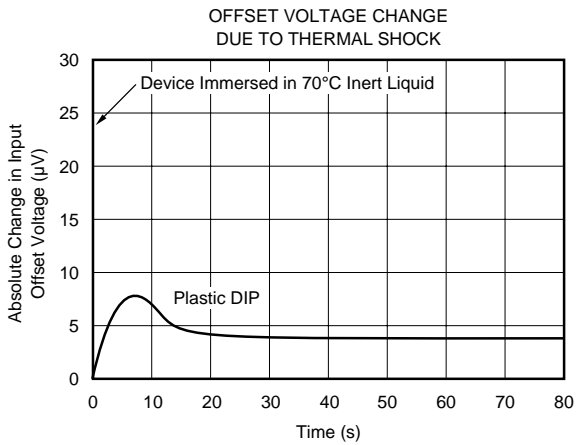
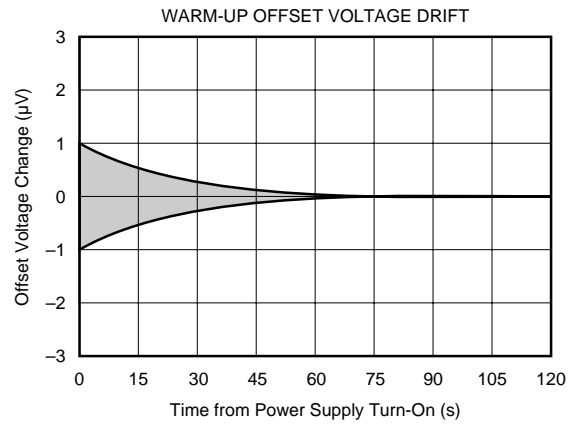
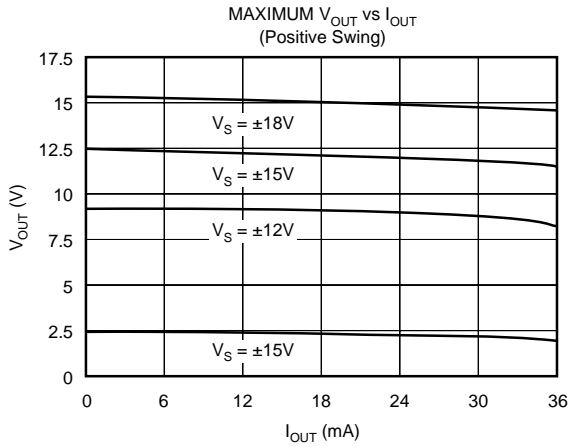
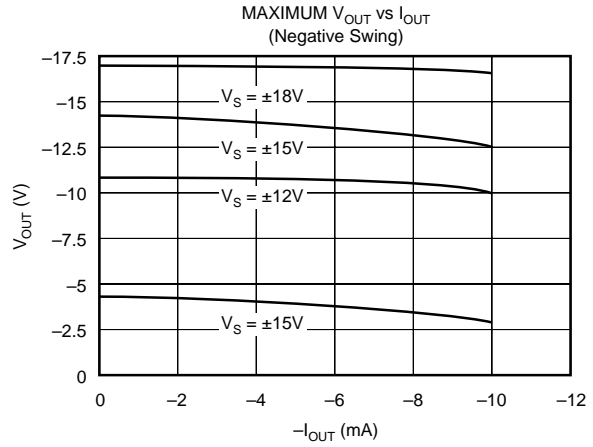
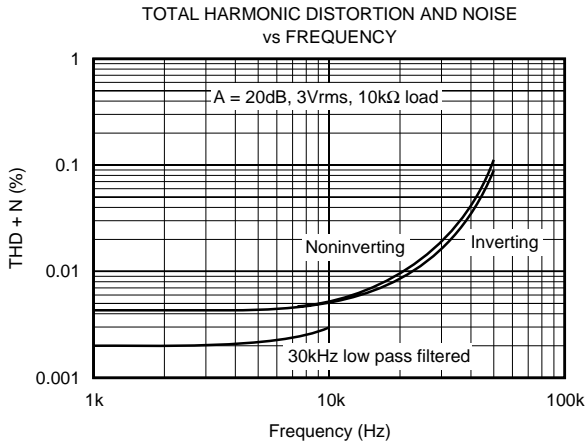

# TYPICAL PERFORMANCE CURVES (CONT)

At  $T_A = +25^\circ\text{C}$ ,  $V_S = \pm 15\text{V}$ , unless otherwise noted.

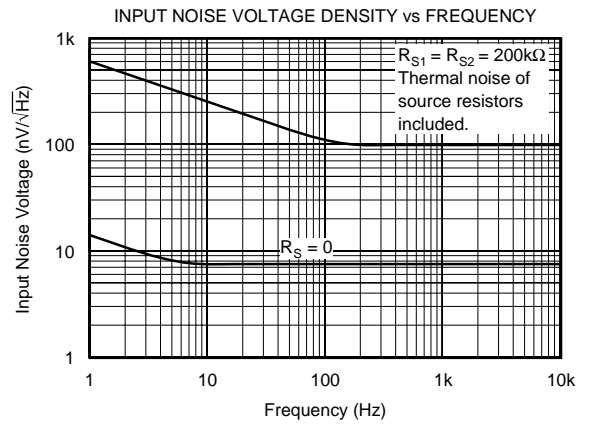
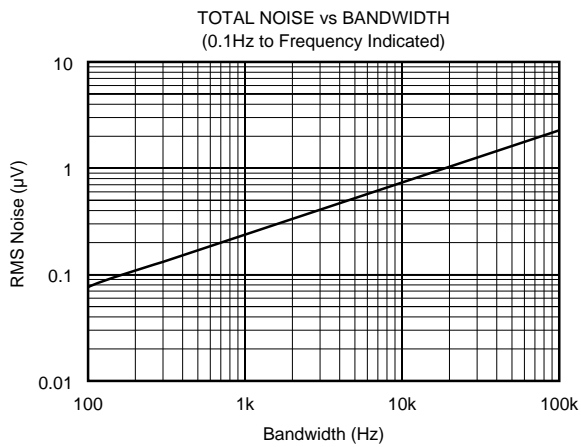
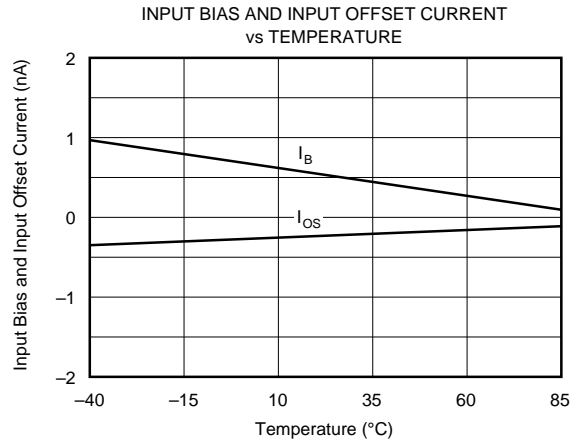
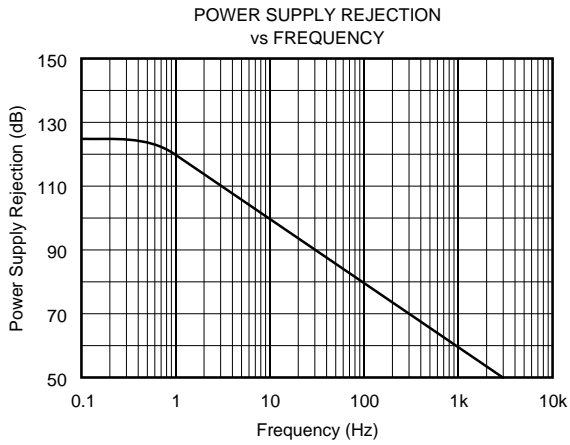
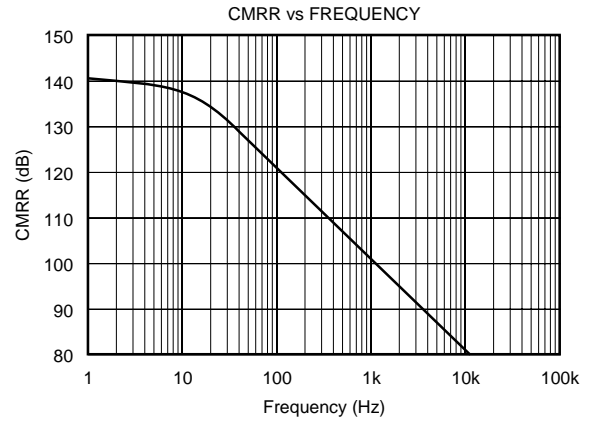
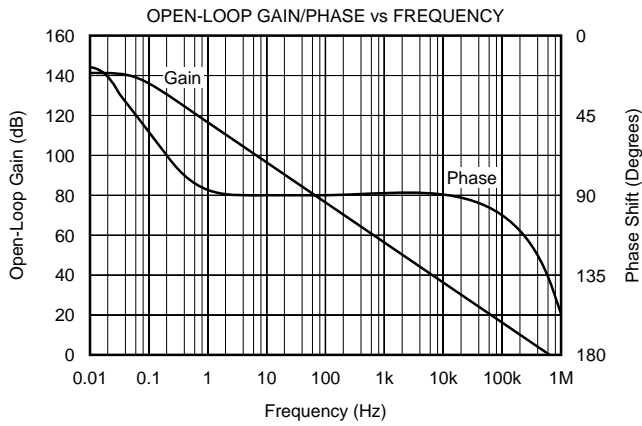

# TYPICAL PERFORMANCE CURVES (CONT)

At  $T_A = +25^\circ\text{C}$ ,  $V_S = \pm 15\text{V}$ , unless otherwise noted.

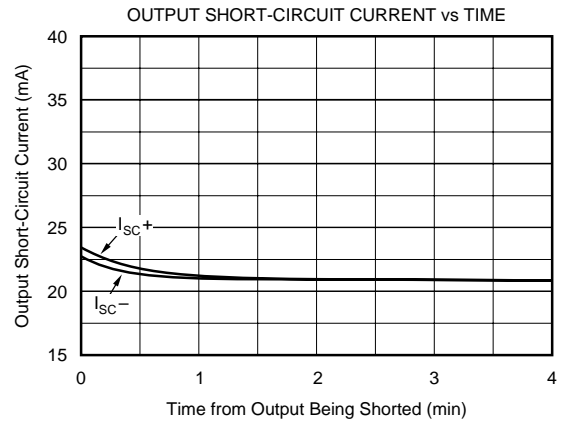
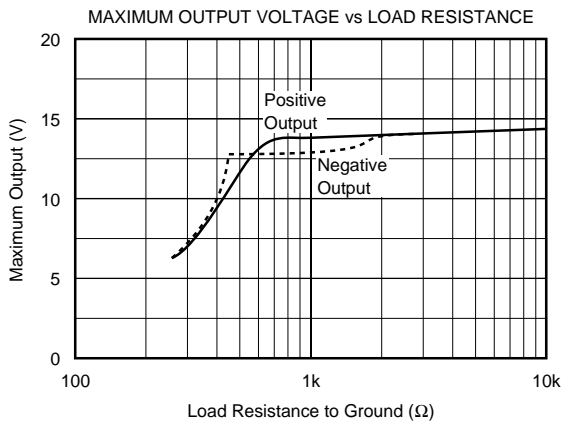
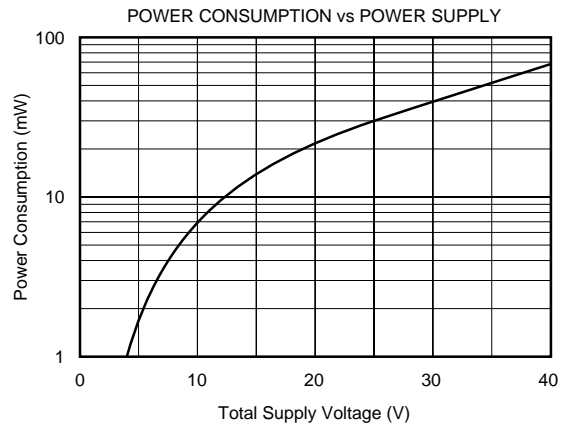
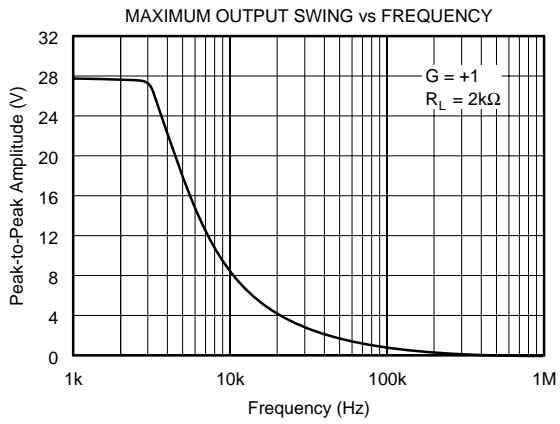

## APPLICATIONS INFORMATION

The OPA177 is unity-gain stable, making it easy to use and free from oscillations in the widest range of circuitry. Applications with noisy or high impedance power supply lines may require decoupling capacitors close to the device pins. In most cases 0.1 $\mu$ F ceramic capacitors are adequate.

The OPA177 has very low offset voltage and drift. To achieve highest performance, circuit layout and mechanical conditions must be optimized. Offset voltage and drift can be degraded by small thermoelectric potentials at the op amp inputs. Connections of dissimilar metals will generate thermal potential which can mask the ultimate performance of the OPA177. These thermal potentials can be made to cancel by assuring that they are equal in both input terminals.

1. Keep connections made to the two input terminals close together.
2. Locate heat sources as far as possible from the critical input circuitry.
3. Shield the op amp and input circuitry from air currents such as cooling fans.

### OFFSET VOLTAGE ADJUSTMENT

The OPA177 has been laser-trimmed for low offset voltage and drift so most circuits will not require external adjustment. Figure 1 shows the optional connection of an external potentiometer to adjust offset voltage. This adjustment should not be used to compensate for offsets created elsewhere in a system since this can introduce excessive temperature drift.

### INPUT PROTECTION

The inputs of the OPA177 are protected with 500 $\Omega$  series input resistors and diode clamps as shown in the simplified circuit diagram. The inputs can withstand  $\pm 30$ V differential inputs without damage. The protection diodes will, of course, conduct current when the inputs are overdriven. This may disturb the slewing behavior of unity-gain follower applications, but will not damage the op amp.

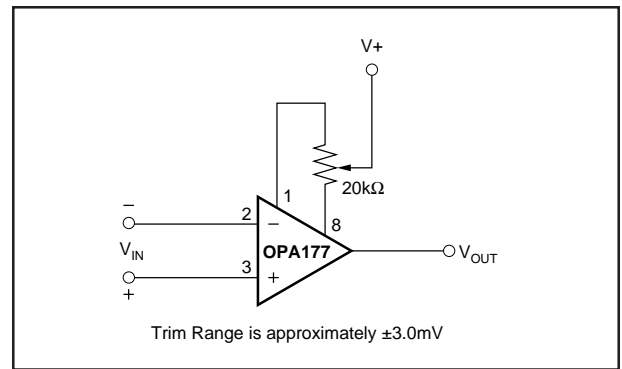

FIGURE 1. Optional Offset Nulling Circuit.

### NOISE PERFORMANCE

The noise performance of the OPA177 is optimized for circuit impedances in the range of 2k $\Omega$  to 50k $\Omega$ . Total noise in an application is a combination of the op amp's input voltage noise and input bias current noise reacting with circuit impedances. For applications with higher source impedance, the OPA627 FET-input op amp will generally provide lower noise. For very low impedance applications, the OPA27 will provide lower noise.

### INPUT BIAS CURRENT CANCELLATION

The input stage base current of the OPA177 is internally compensated with an equal and opposite cancellation current. The resulting input bias current is the difference between the input stage base current and the cancellation current. This residual input bias current can be positive or negative.

When the bias current is cancelled in this manner, the input bias current and input offset current are approximately the same magnitude. As a result, it is not necessary to balance the DC resistance seen at the two input terminals (Figure 2). A resistor added to balance the input resistances may actually increase offset and noise.

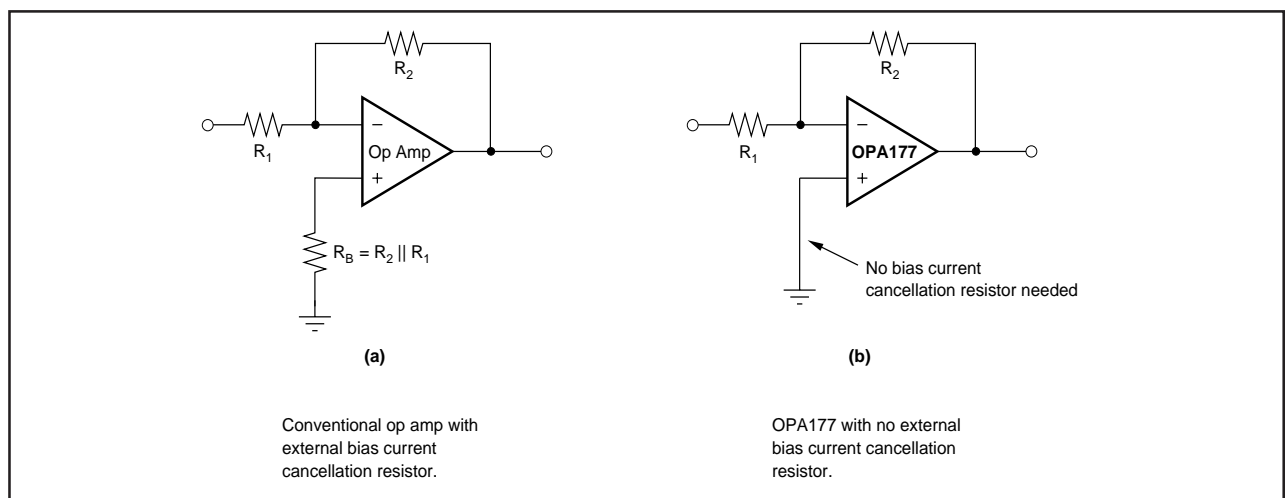

FIGURE 2. Input Bias Current Cancellation.