

BIPOLAR ANALOG INTEGRATED CIRCUIT

μ PC4082

J-FET INPUT DUAL OPERATIONAL AMPLIFIER

DESCRIPTION

The μ PC4082 is a dual operational amplifier incorporating well matched ion implant P-channel J-FET on the same chip with standard bipolar transistors. The key features of this op amp is very low input bias current and high slew rate for ten times faster than conventional general purpose op amps. By these features the μ PC4082 is excellent choice for wide variety of applications including integrator, active filter, pulse amp etc.

FEATURES

- Low noise: $e_n = 25 \text{ nV}/\sqrt{\text{Hz}}$ (TYP.)
- Very low input bias and offset currents
- Output short circuit protection
- High input impedance...J-FET Input stage
- Internal frequency compensation
- High slew rate...13 V/ μ s (TYP.)

ORDERING INFORMATION

Part Number	Package
μ PC4082C	8-pin plastic DIP (7.62 mm (300))
μ PC4082G2	8-pin plastic SOP (5.72 mm (225))

EQUIVALENT CIRCUIT

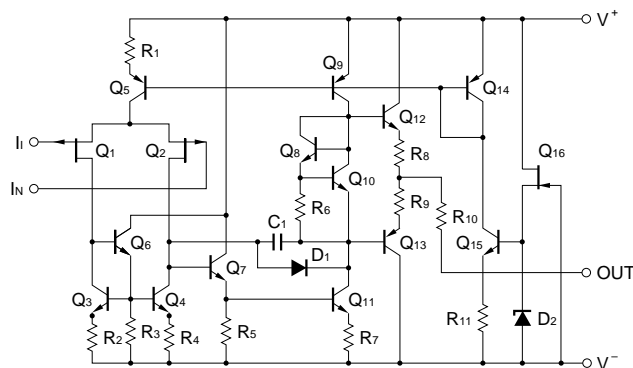

PIN CONFIGURATION (Top View)

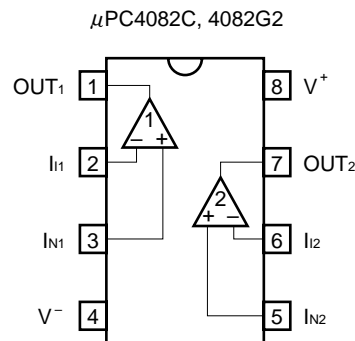

The information in this document is subject to change without notice. Before using this document, please confirm that this is the latest version.
 Not all devices/types available in every country. Please check with local NEC representative for availability and additional information.

ABSOLUTE MAXIMUM RATINGS (T_A = 25°C)

Parameter		Symbol	Ratings	Unit
Voltage between V ⁺ and V ⁻ ^{Note 1}		V ⁺ - V ⁻	-0.3 to +36	V
Differential Input Voltage		V _{ID}	±30	V
Input Voltage ^{Note 2}		V _I	V ⁻ -0.3 to V ⁺ +0.3	V
Output Voltage ^{Note 3}		V _O	V ⁻ -0.3 to V ⁺ +0.3	V
Power Dissipation	C Package ^{Note 4}	P _T	350	mW
	G2 Package ^{Note 5}		440	mW
Output Short Circuit Duration ^{Note 6}			Indefinite	sec
Operating Ambient Temperature		T _A	-20 to +80	°C
Storage Temperature		T _{stg}	-55 to +125	°C

- Notes**
- Reverse connection of supply voltage can cause destruction.
 - The input voltage should be allowed to input without damage or destruction. Even during the transition period of supply voltage, power on/off etc., this specification should be kept. The normal operation will establish when the both inputs are within the Common Mode Input Voltage Range of electrical characteristics.
 - This specification is the voltage which should be allowed to supply to the output terminal from external without damage or destructive. Even during the transition period of supply voltage, power on/off etc., this specification should be kept. The output voltage of normal operation will be the Output Voltage Swing of electrical characteristics.
 - Thermal derating factor is -5.0 mV/°C when operating ambient temperature is higher than 55°C.
 - Thermal derating factor is -4.4 mV/°C when operating ambient temperature is higher than 25°C.
 - Pay careful attention to the total power dissipation not to exceed the absolute maximum ratings, Note 4 and Note 5.

RECOMMENDED OPERATING CONDITIONS

Parameter	Symbol	MIN.	TYP.	MAX.	Unit
Supply Voltage	V [±]	±5		±16	V
★ Output Current	I _o			±10	mA
★ Capacitive Load (A _v = +1, R _f = 0 Ω)	C _L			100	pF

ELECTRICAL CHARACTERISTICS (T_A = 25°C, V[±] = ±15 V)

Parameter	Symbol	Conditions	MIN.	TYP.	MAX.	Unit
Input Offset Voltage	V _{IO}	R _S ≤ 50 Ω		±5	±15	mV
Input Offset Current ^{Note 7}	I _{IO}			±5	±200	pA
Input Bias Current ^{Note 7}	I _B			30	400	pA
Large Signal Voltage Gain	A _V	R _L ≥ 2 kΩ, V _O = ±10 V	25000	200000		
Supply Current	I _{CC}	I _O = 0 A, Both Amplifiers		4.0	5.6	mA
Common Mode Rejection Ratio	CMR		70	76		dB
Supply Voltage Rejection Ratio	SVR		70	76		dB
Output Voltage Swing	V _{OM}	R _L ≥ 10 kΩ	±12	±13.5		V
		R _L ≥ 2 kΩ	±10	±12		V
Common Mode Input Voltage Range	V _{ICM}		±10	+15 -12.7		V
Slew Rate	SR	A _V = 1		13		V/μs
Unity Gain Frequency	f _{unity}			3		MHz
Input Equivalent Noise Voltage Density	e _n	R _S = 100 Ω, f = 1 kHz		25		nV/√Hz
Channel Separation				120		dB
Input Offset Voltage	V _{IO}	R _S ≤ 50 Ω, T _A = -20 to +70°C			±20	mV
Average V _{IO} Temperature Drift	ΔV _{IO} /ΔT	T _A = -20 to +70°C		±10		μV/°C
Input Offset Current ^{Note 7}	I _{IO}	T _A = -20 to +70°C			±5	nA
Input Bias Current ^{Note 7}	I _B	T _A = -20 to +70°C			10	nA

Notes 7. Input bias currents flow into IC. Because each currents are gate leak current of P-channel J-FET on input stage. And that are temperature sensitive. Short time measuring method is recommendable to maintain the junction temperature close to the operating ambient temperature.

TYPICAL PERFORMANCE CHARACTERISTICS ($T_A = 25^\circ\text{C}$, TYP.)

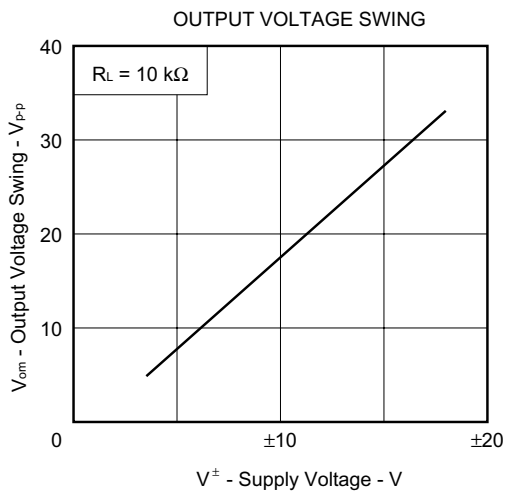
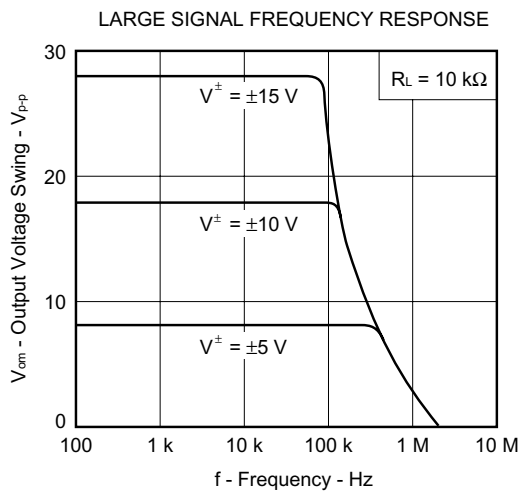
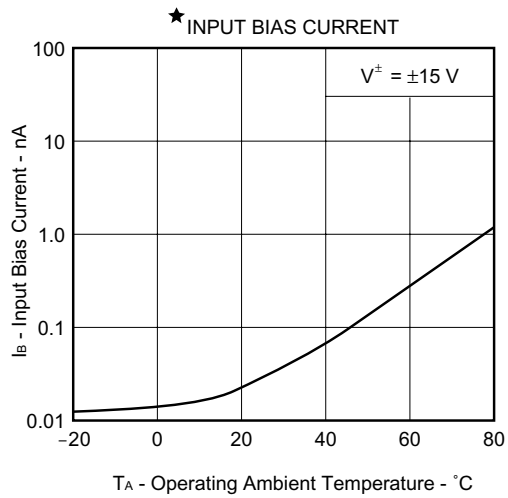
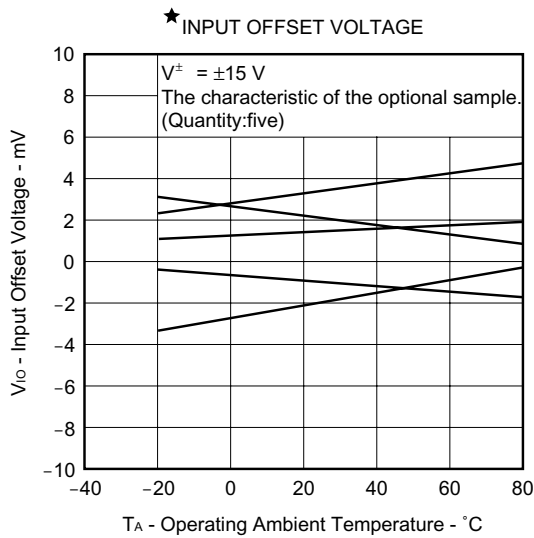
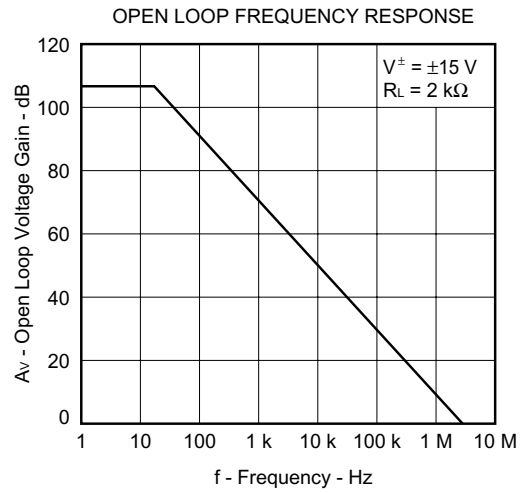
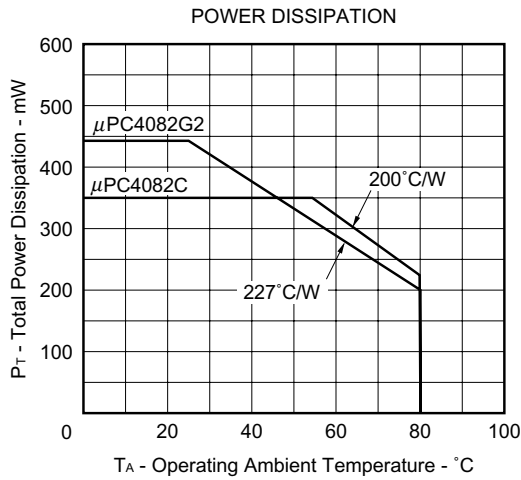

OUTPUT VOLTAGE SWING

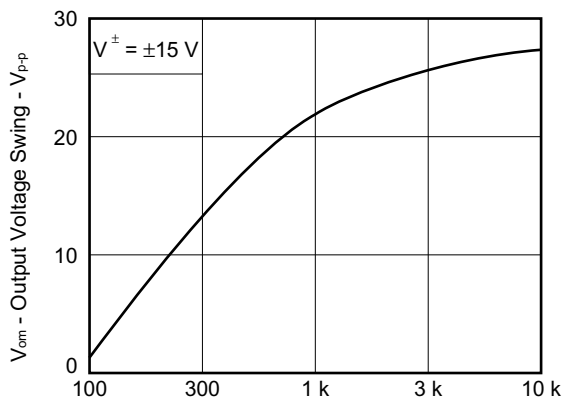

R_L - Load Resistance - Ω

SUPPLY CURRENT

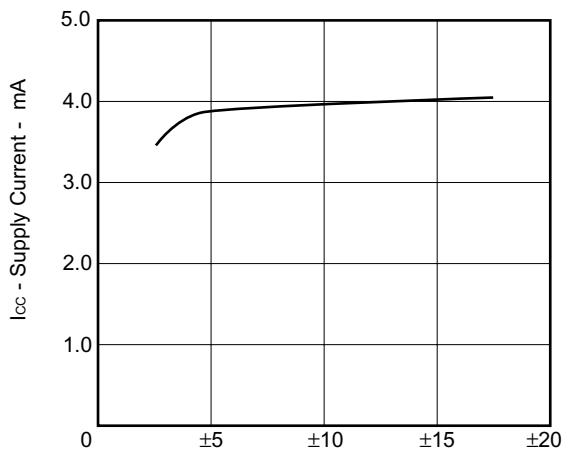

V^{\pm} - Supply Voltage - V

INPUT EQUIVALENT NOISE VOLTAGE DENSITY

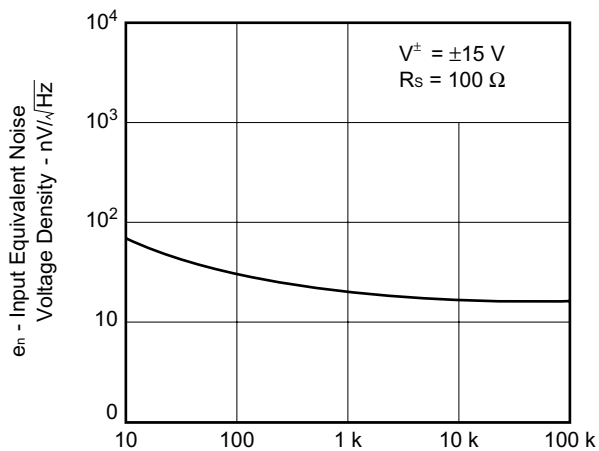

f - Frequency - Hz

VOLTAGE FOLLOWER PULSE RESPONSE

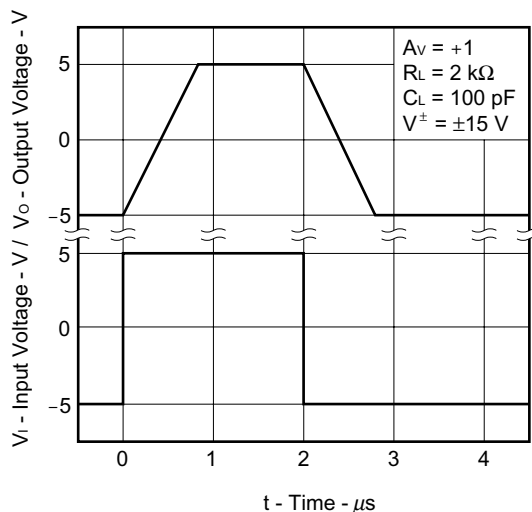

t - Time - μ s

★ PACKAGE DRAWINGS (Unit : mm)

8-PIN PLASTIC DIP (7.62mm(300))

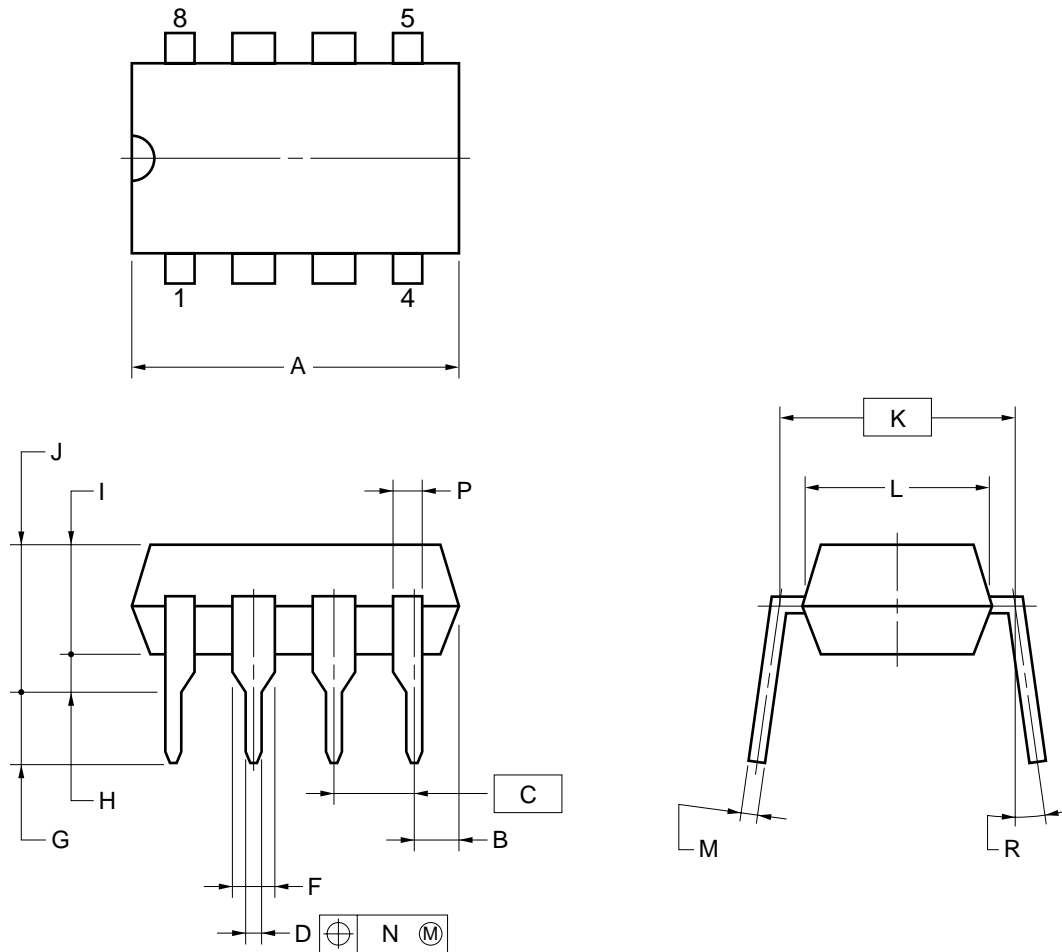

NOTES

1. Each lead centerline is located within 0.25 mm of its true position (T.P.) at maximum material condition.
2. Item "K" to center of leads when formed parallel.

ITEM	MILLIMETERS
A	10.16 MAX.
B	1.27 MAX.
C	2.54 (T.P.)
D	0.50±0.10
F	1.4 MIN.
G	3.2±0.3
H	0.51 MIN.
I	4.31 MAX.
J	5.08 MAX.
K	7.62 (T.P.)
L	6.4
M	0.25 ^{+0.10} _{-0.05}
N	0.25
P	0.9 MIN.
R	0~15°

P8C-100-300B,C-2

8-PIN PLASTIC SOP (5.72 mm (225))

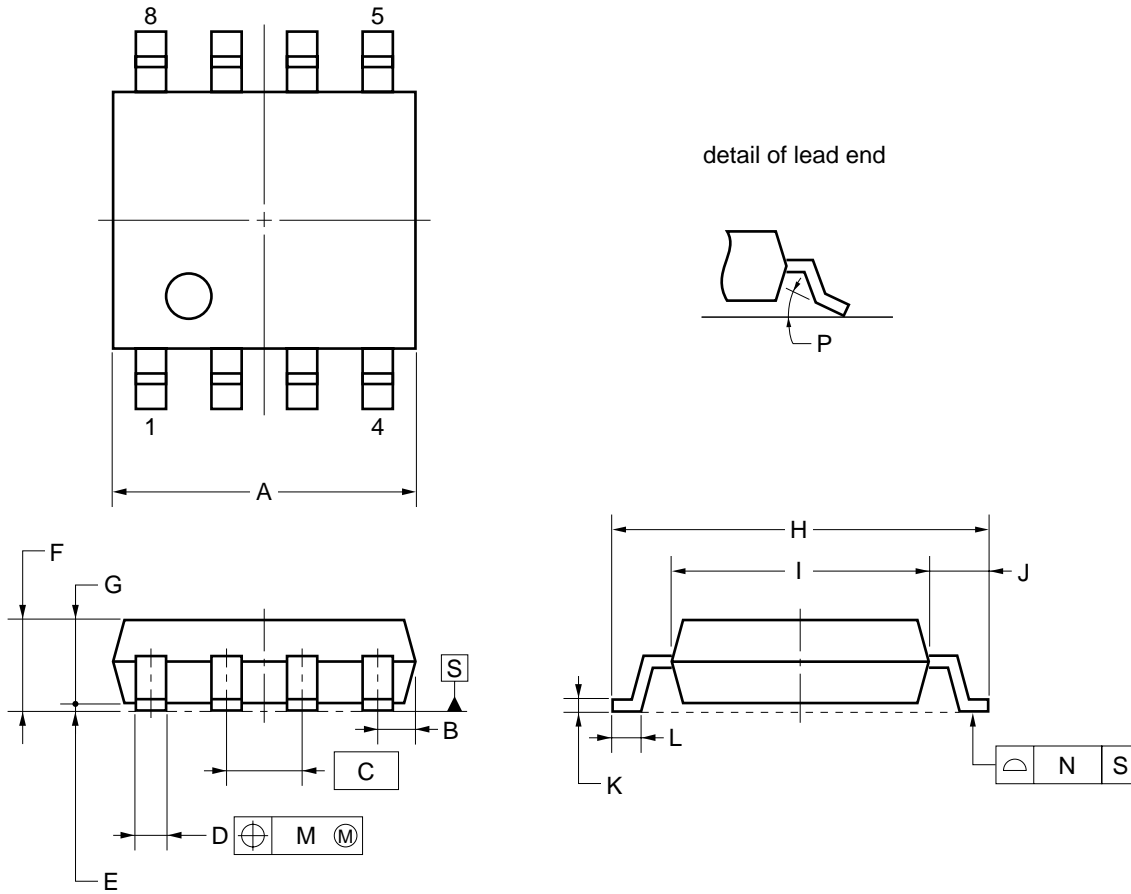

NOTE

Each lead centerline is located within 0.12 mm of its true position (T.P.) at maximum material condition.

ITEM	MILLIMETERS
A	5.2 ^{+0.17} / _{-0.20}
B	0.78 MAX.
C	1.27 (T.P.)
D	0.42 ^{+0.08} / _{-0.07}
E	0.1±0.1
F	1.59±0.21
G	1.49
H	6.5±0.3
I	4.4±0.15
J	1.1±0.2
K	0.17 ^{+0.08} / _{-0.07}
L	0.6±0.2
M	0.12
N	0.10
P	3° ^{+7°} / _{-3°}

S8GM-50-225B-6

★ **RECOMMENDED SOLDERING CONDITIONS**

When soldering this product, it is highly recommended to observe the conditions as shown below. If other soldering processes are used, or if the soldering is performed under different conditions, please make sure to consult with our sales offices.

For more details, refer to our document "SEMICONDUCTOR DEVICE MOUNTING TECHNOLOGY MANUAL"(C10535E).

Type of Surface Mount Device

μPC4082G2: 8-pin plastic SOP (5.72 mm (225))

Process	Conditions	Symbol
Infrared Ray Reflow	Peak temperature: 230°C or below (Package surface temperature), Reflow time: 30 seconds or less (at 210°C or higher), Maximum number of reflow processes: 1 time.	IR30-00-1
Vapor Phase Soldering	Peak temperature: 215°C or below (Package surface temperature), Reflow time: 40 seconds or less (at 200°C or higher), Maximum number of reflow processes: 1 time.	VP15-00-1
Wave Soldering	Solder temperature: 260°C or below, Flow time: 10 seconds or less, Maximum number of flow processes: 1 time, Pre-heating temperature: 120°C or below (Package surface temperature).	WS60-00-1
Partial Heating Method	Pin temperature: 300°C or below, Heat time: 3 seconds or less (Per each side of the device).	—

Caution Apply only one kind of soldering condition to a device, except for "partial heating method", or the device will be damaged by heat stress.

Type of Through-hole Device

μPC4082C: 8-pin plastic DIP (7.62 mm (300))

Process	Conditions
Wave Soldering (only to leads)	Solder temperature: 260°C or below, Flow time: 10 seconds or less.
Partial Heating Method	Pin temperature: 300°C or below, Heat time: 3 seconds or less (per each lead).

Caution For through-hole device, the wave soldering process must be applied only to leads, and make sure that the package body does not get jet soldered.

[MEMO]

[MEMO]

[MEMO]

- **The information in this document is current as of March, 2001. The information is subject to change without notice. For actual design-in, refer to the latest publications of NEC's data sheets or data books, etc., for the most up-to-date specifications of NEC semiconductor products. Not all products and/or types are available in every country. Please check with an NEC sales representative for availability and additional information.**
- No part of this document may be copied or reproduced in any form or by any means without prior written consent of NEC. NEC assumes no responsibility for any errors that may appear in this document.
- NEC does not assume any liability for infringement of patents, copyrights or other intellectual property rights of third parties by or arising from the use of NEC semiconductor products listed in this document or any other liability arising from the use of such products. No license, express, implied or otherwise, is granted under any patents, copyrights or other intellectual property rights of NEC or others.
- Descriptions of circuits, software and other related information in this document are provided for illustrative purposes in semiconductor product operation and application examples. The incorporation of these circuits, software and information in the design of customer's equipment shall be done under the full responsibility of customer. NEC assumes no responsibility for any losses incurred by customers or third parties arising from the use of these circuits, software and information.
- While NEC endeavours to enhance the quality, reliability and safety of NEC semiconductor products, customers agree and acknowledge that the possibility of defects thereof cannot be eliminated entirely. To minimize risks of damage to property or injury (including death) to persons arising from defects in NEC semiconductor products, customers must incorporate sufficient safety measures in their design, such as redundancy, fire-containment, and anti-failure features.
- NEC semiconductor products are classified into the following three quality grades:
"Standard", "Special" and "Specific". The "Specific" quality grade applies only to semiconductor products developed based on a customer-designated "quality assurance program" for a specific application. The recommended applications of a semiconductor product depend on its quality grade, as indicated below. Customers must check the quality grade of each semiconductor product before using it in a particular application.
"Standard": Computers, office equipment, communications equipment, test and measurement equipment, audio and visual equipment, home electronic appliances, machine tools, personal electronic equipment and industrial robots
"Special": Transportation equipment (automobiles, trains, ships, etc.), traffic control systems, anti-disaster systems, anti-crime systems, safety equipment and medical equipment (not specifically designed for life support)
"Specific": Aircraft, aerospace equipment, submersible repeaters, nuclear reactor control systems, life support systems and medical equipment for life support, etc.
The quality grade of NEC semiconductor products is "Standard" unless otherwise expressly specified in NEC's data sheets or data books, etc. If customers wish to use NEC semiconductor products in applications not intended by NEC, they must contact an NEC sales representative in advance to determine NEC's willingness to support a given application.
(Note)
(1) "NEC" as used in this statement means NEC Corporation and also includes its majority-owned subsidiaries.
(2) "NEC semiconductor products" means any semiconductor product developed or manufactured by or for NEC (as defined above).