



The ACCU-GUARD fuse is based on thin-film technologies. This technology provides a level of control on the component electrical and physical characteristic that is generally not possible with standard fuse technologies. This has allowed AVX to offer a device which is designed for modern surface mount circuit boards which require protection.

Features

- Accurate current rating/fusing characteristic
- Fast acting fuse (within 5 sec at I rated × 2)
- Rated Voltage : 32V, 63V
- Current Rating : 0.2A to 5.0A
- Insulation Resistance : >20MΩ (after fusing at rated voltage)

How to Order

F0805 B 1R50 F W TR M
① ② ③ ④ ⑤ ⑥ ⑦

① Size (mm)

0402	1.0×0.55
0603	1.6×0.8
0805	2.0×1.25
0612	1.6×3.2

② Base Material

B	Aluminum sbst
C	Aluminum sbst + Glass Ceramic
D	Aluminum Sbst.
E	Glass Ceramic

③ Rated Voltage

④ Type (F : Fast Blow)

⑤ Termination

W	Ni Plate Termination
----------	----------------------

⑥ Packaging (TR : Taping)

⑦ Marking (M : Marked)

Dimensions

(Unit : mm)

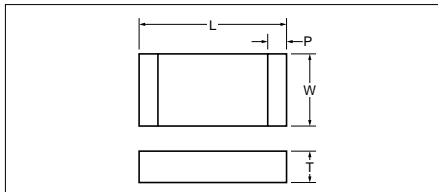

	L	W	T	P
0402	1.00±0.1	0.55±0.07	0.4±0.1	0.2±0.1
0603	1.65±0.15	0.8±0.15	0.7±0.15	0.35±0.15
0805	2.1±0.2	1.27±0.1	0.9±0.2	0.3±0.15
0612	1.65±0.25	3.1±0.2	0.9±0.2	0.35±0.15

Applications

- Computer
- Hard disc drives
- Switching power supplies
- Telecommunication

Approvals

- Recognized by Underwriters Laboratories, Inc. UL CUL : Rcd #E 143842

Specifications

Size	0402E	0603C	0805B	0612D
Operating Temperature	-55°C to +125°C			
Current Carrying Capacity	-55°C 107% of rating			
	+25°C 100% of rating			
Rated Voltage	+85°C 85% of rating	+85°C 90% of rating	+85°C 93% of rating	+85°C 80% of rating
	+125°C 80% of rating	+125°C 75% of rating	+125°C 90% of rating	+125°C 75% of rating
Rated Voltage	32VDC	16 to 32VDC	63VDC	32VDC
Interrupting	50A			
Insulation Resistance	>20MΩ			

Part No.	Rated Voltage [V]	Current Rating [A]	Resistance @10%I rated, 25°C max [Ω]	Voltage Drop @ 1:I rated, 25°C max [mV]	Fusing Current (within 5 sec.) 25°C [A]	Pre-Are I ² t@50A [A ² sec.]	Marking Code	
F0402E0R20FSTRM	32	0.20	1.000	300	0.50	0.00003	■	White
F0402E0R25FSTRM	32	0.25	0.650	220	0.625	0.00005	■	Black
F0402E0R50FSTRM	32	0.50	0.250	180	1.25	0.0003	■	Blue
F0402E1R00FSTRM	32	1.00	0.130	160	2.50	0.008	■	Green
F0402E1R50FSTRM	32	1.50	0.060	140	3.75	0.03	■	White
F0402E2R00FSTRM	32	2.00	0.050	120	5.00	0.06	■	Brown
F0603E0R25FSTR	32	0.25	0.650	220	0.625	0.00005	■	Black
F0603E0R50FSTR	32	0.50	0.250	180	1.25	0.0003	■	Blue
F0603E1R00FSTR	32	1.00	0.130	160	2.50	0.008	■	Green
F0603E1R40FSTR	32	1.40	0.060	100	3.50	0.02	■	Black
F0603E1R50FSTR	32	1.50	0.060	140	3.75	0.03	■	White
F0603E2R00FSTR	32	2.00	0.050	120	5.00	0.06	■	Brown
F0603C0R15FWTRM	32	0.150	1.750(1.300typ.)	400	0.30	0.000004	▲	Green
F0603C0R25FWTRM	32	0.25	0.800	280	0.50	0.00003	■	Black
F0603C0R37FWTRM	32	0.375	0.500	280	0.75	0.0001	▲	Blue
F0603C0R50FWTRM	32	0.50	0.320	280	1.00	0.0002	■	Blue
F0603C0R75FWTRM	32	0.75	0.300	280	1.50	0.0015	▲	Yellow
F0603C1R00FWTRM	32	1.00	0.200	240	2.00	0.004	■	Green
F0603C1R25FWTRM	32	1.25	0.170	240	2.50	0.007	■	Yellow
F0603C1R50FWTRM	32	1.50	0.110	240	3.00	0.012	■	White
F0603C1R75FWTRM	24	1.75	0.090	240	3.50	0.02	▲	Brown
F0603C2R00FWTRM	24	2.00	0.075	240	4.00	0.03	■	Brown
F0603C2R50FWTRM	16	2.50	0.055	200	5.00	0.05	▲	Red
F0603C3R00FWTRM	16	3.00	0.045	200	6.00	0.10	■	Red
F0805B0R25FWTRM	63	0.250	0.750	280	0.50	0.00003		F2
F0805B0R50FWTRM	63	0.500	0.350	280	1.00	0.0002		H2
F0805B0R75FWTRM	63	0.750	0.270	280	1.50	0.001		K2
F0805B1R00FWTRM	63	1.000	0.220	280	2.00	0.003		12
F0805B1R25FWTRM	63	1.250	0.170	280	2.50	0.007		P2
F0805B1R50FWTRM	63	1.500	0.120	240	3.00	0.010		L2
F0805B2R00FWTRM	63	2.000	0.080	220	4.00	0.030		22
F0805B2R50FWTRM	63	2.500	0.060	220	5.00	0.050		V2
F0805B3R00FWTRM	63	3.000	0.050	220	6.00	0.10		32
*F0612D4R00FWTR	32	4.00	0.040	260	10.0	0.10		41
*F0612D5R00FWTR	32	5.00	0.025	200	12.5	0.25		51

*1206 size chip (A Type) fuse is also available.

Packaging

All tape and reel specifications are in compliance with EIA RS481 (IEC 285 Part 3)

- Tape width : 8mm
- Packing Quantity : 3000pcs.

• Reel Dimensions

(Unit : mm)

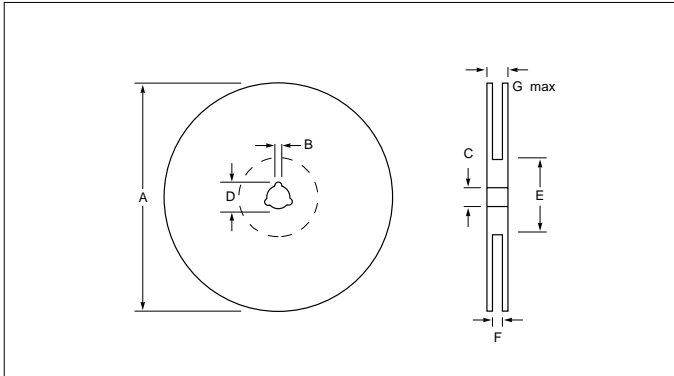

Code	A	B	C	D	E	F	G
Dimension	180±1.0	1.5min	13±0.2	20.2min	50min	9.4±1.5	14.4max

• Carrier Tape Dimensions

(Unit : mm)

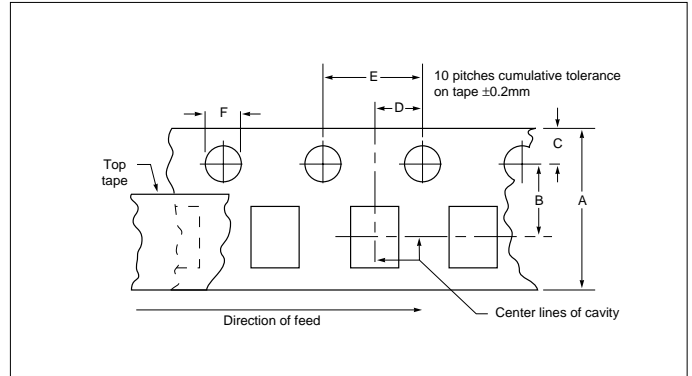

Code	A	B	C	D	E	F
Dimension	8.0±0.3	3.5±0.05	1.75±0.1	2.0±0.05	4.0±0.1	1.5 ^{+0.1} _{0.0}

The normal dimensions of the component compartment are derived from the component size.

Fuse-Time-Current Characteristics

