

# LM101A, LM201A, LM301A HIGH-PERFORMANCE OPERATIONAL AMPLIFIERS

D961, OCTOBER 1979 – REVISED SEPTEMBER 1990

- **Low Input Currents**
- **Low Input Offset Parameters**
- **Frequency and Transient Response Characteristics Adjustable**
- **Short-Circuit Protection**
- **Offset-Voltage Null Capability**
- **No Latch-Up**
- **Wide Common-Mode and Differential Voltage Ranges**
- **Same Pin Assignments as uA709**
- **Designed to be Interchangeable with National Semiconductor LM101A and LM301A**

## description

The LM101A, LM201A, and LM301A are high-performance operational amplifiers featuring very low input bias current and input offset voltage and current to improve the accuracy of high-impedance circuits using these devices. The high common-mode input voltage range and the absence of latch-up make these amplifiers ideal for voltage-follower applications. The devices are protected to withstand short circuits at the output. The external compensation of these amplifiers allows the changing of the frequency response (when the closed-loop gain is greater than unity) for applications requiring wider bandwidth or higher slew rate. A potentiometer may be connected between the offset-null inputs (N1 and N2), as shown in Figure 7, to null out the offset voltage.

The LM101A is characterized for operation over the full military temperature range of  $-55^{\circ}\text{C}$  to  $125^{\circ}\text{C}$ , the LM201A is characterized for operation from  $-25^{\circ}\text{C}$  to  $85^{\circ}\text{C}$ , and the LM301A is characterized for operation from  $0^{\circ}\text{C}$  to  $70^{\circ}\text{C}$ .

## symbol

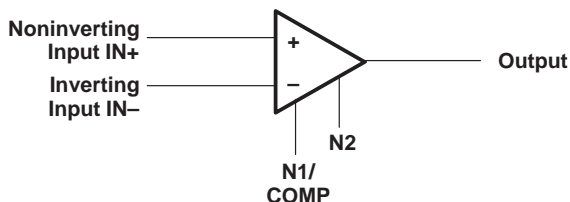

**D, JG, OR P PACKAGE  
(TOP VIEW)**

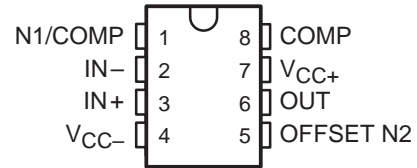

**LM101A  
W FLAT PACKAGE  
(TOP VIEW)**

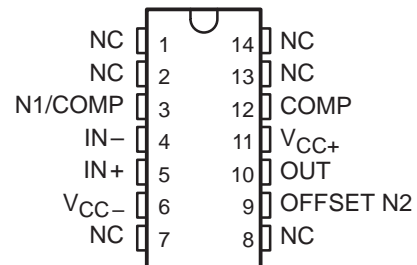

**LM101A  
U FLAT PACKAGE  
(TOP VIEW)**

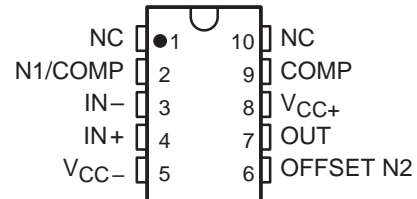

**LM101A  
FK CHIP-CARRIER PACKAGE  
(TOP VIEW)**

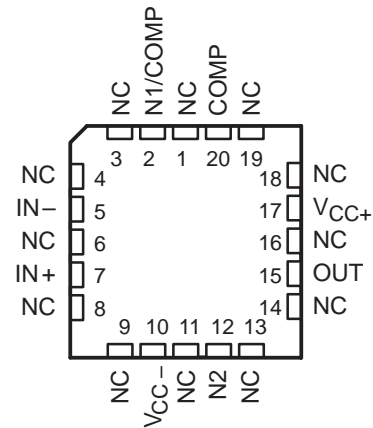

NC – No internal connection

PRODUCTION DATA information is current as of publication date. Products conform to specifications per the terms of Texas Instruments standard warranty. Production processing does not necessarily include testing of all parameters.



POST OFFICE BOX 655303 • DALLAS, TEXAS 75265

Copyright © 1991, Texas Instruments Incorporated

# LM101A, LM201A, LM301A HIGH-PERFORMANCE OPERATIONAL AMPLIFIERS

## AVAILABLE OPTIONS

T <sub>A</sub>	V <sub>IO</sub> MAX at 25°C	PACKAGE					
		SMALL OUTLINE (D)	CHIP CARRIER (FK)	CERAMIC DIP (JG)	PLASTIC DIP (P)	FLAT PACK (U)	FLAT PACK (W)
0°C to 70°C	7.5 mV	LM301AD	–	–	LM301AP	–	–
–25°C to 85°C	2 mV	LM201AD	–	–	LM201AP	–	–
–55°C to 125°C	2 mV	LM101AD	LM101AFK	LM101AJG	LM101AP	LM101AU	LM101AW

The D package is available taped and reeled. Add the suffix R to the device type, (i.e., LM301ADR).

## absolute maximum ratings over operating free-air temperature range (unless otherwise noted)

	LM101A	LM201A	LM301A	UNIT
Supply voltage V <sub>CC+</sub> (see Note 1)	22	22	18	V
Supply voltage V <sub>CC–</sub> (see Note 1)	–22	–22	–18	V
Differential input voltage (see Note 2)	±30	±30	±30	V
Input voltage (either input, see Notes 1 and 3)	±15	±15	±15	V
Voltage between either offset null terminal (N1/N2) and V <sub>CC–</sub>	–0.5 to 2	–0.5 to 2	–0.5 to 2	V
Duration of output short-circuit (see Note 4)	unlimited	unlimited	unlimited	
Continuous total power dissipation	See Dissipation Rating Table			
Operating free-air temperature range	–55 to 125	–25 to 85	0 to 70	°C
Storage temperature range	–65 to 150	–65 to 150	–65 to 150	°C
Case temperature for 60 seconds: FK package	260			°C
Lead temperature 1,6 mm (1/16 inch) from case for 60 seconds	JG, U, or W package			°C
Lead temperature 1,6 mm (1/16 inch) from case for 10 seconds	D or P package		260	°C

- NOTES: 1. All voltage values, unless otherwise noted, are with respect to the midpoint between V<sub>CC+</sub> and V<sub>CC–</sub>.  
 2. Differential voltages are at the noninverting input terminal with respect to the inverting input terminal.  
 3. The magnitude of the input voltage must never exceed the magnitude of the supply voltage or 15 V, whichever is less.  
 4. The output may be shorted to ground or either power supply. For the LM101A only, the unlimited duration of the short-circuit applies at (or above) 125°C case temperature or 75°C free-air temperature. For the LM201A only, the unlimited duration of the short-circuit applies at (or below) 85°C case temperature or 75°C free-air temperature.

## DISSIPATION RATING TABLE

PACKAGE	T <sub>A</sub> ≤ 25°C POWER RATING	DERATING FACTOR	DERATE ABOVE T <sub>A</sub>	T <sub>A</sub> = 70°C POWER RATING	T <sub>A</sub> = 85°C POWER RATING	T <sub>A</sub> = 125°C POWER RATING
D	500 mW	5.8 mW/°C	64°C	464 mW	377 mW	145 mW
FK	500 mW	11.0 mW/°C	105°C	500 mW	500 mW	275 mW
JG	500 mW	8.4 mW/°C	90°C	500 mW	500 mW	210 mW
P	500 mW	8.0 mW/°C	87°C	500 mW	500 mW	200 mW
U	500 mW	5.4 mW/°C	57°C	432 mW	351 mW	135 mW
W	500 mW	8.0 mW/°C	87°C	500 mW	500 mW	200 mW

## recommended operating conditions

	MIN	MAX	UNIT
Supply voltage, V <sub>CC+</sub>	5	18	V
Supply voltage, V <sub>CC–</sub>	–5	–18	



**electrical characteristics at specified free-air temperature,  $C_C = 30$  pF (see Note 5)**

PARAMETER		TEST CONDITIONS†		LM101A, LM201A			LM301A			UNIT
				MIN	TYP	MAX	MIN	TYP	MAX	
$V_{IO}$	Input offset voltage	$V_O = 0$	25°C	0.6	2		2	7.5	mV	
			Full range			3		10		
$\alpha_{VIO}$	Average temperature coefficient of input offset voltage	$V_O = 0$	Full range	3	15		6	30	$\mu\text{V}/^\circ\text{C}$	
$I_{IO}$	Input offset current		25°C	1.5	10		3	50	nA	
			Full range			20		70		
$\alpha_{IIO}$	Average temperature coefficient of input offset current		$T_A = -55^\circ\text{C}$ to $25^\circ\text{C}$	0.02	0.2				nA/ $^\circ\text{C}$	
			$T_A = 25^\circ\text{C}$ to MAX	0.01	0.1					
			$T_A = 0^\circ\text{C}$ to $25^\circ\text{C}$				0.02	0.6		
			$T_A = 25^\circ\text{C}$ to $70^\circ\text{C}$				0.01	0.3		
$I_{IB}$	Input bias current		25°C	30	75		70	250	nA	
			Full range			100		300		
$V_{ICR}$	Common-mode input voltage range	See Note 6	Full range	$\pm 15$			$\pm 12$		V	
$V_{OPP}$	Maximum peak-to-peak output voltage swing	$V_{CC\pm} = \pm 15$ V, $R_L = 10$ k $\Omega$	25°C	24	28		24	28	V	
			Full range	24			24			
		$V_{CC\pm} = \pm 15$ V, $R_L = 2$ k $\Omega$	25°C	20	26		20	26		
			Full range	20			20			
$A_{VD}$	Large-signal differential voltage amplification	$V_{CC\pm} = \pm 15$ V, $V_O = \pm 10$ V, $R_L \geq 2$ k $\Omega$	25°C	50	200		25	200	V/mV	
			Full range	25			15			
$r_i$	Input resistance		25°C	1.5	4		0.5	2	M $\Omega$	
CMRR	Common-mode rejection ratio	$V_{IC} = V_{ICR}$ min	25°C	80	98		70	90	dB	
			Full range	80			70			
$k_{SVR}$	Supply voltage rejection ratio ( $\Delta V_{CC}/\Delta V_{IO}$ )		25°C	80	98		70	96	dB	
			Full range	80			70			
$I_{CC}$	Supply current	No load, $V_O = 0$ , See Note 6	25°C	1.8	3		1.8	3	mA	
			MAX	1.2	2.5					

† All characteristics are measured under open-loop conditions with zero common-mode input voltage unless otherwise specified. Full range for LM101A is  $-55^\circ\text{C}$  to  $125^\circ\text{C}$ , for LM201A is  $-25^\circ\text{C}$  to  $85^\circ\text{C}$ , and for LM301A is  $0^\circ\text{C}$  to  $70^\circ\text{C}$ .

NOTES: 5. Unless otherwise noted,  $V_{CC\pm} = \pm 5$  V to  $\pm 20$  V for LM101A and LM201A, and  $V_{CC\pm} = \pm 5$  V to  $\pm 15$  V for LM301A. All typical values are at  $V_{CC\pm} = \pm 15$  V.

6. For LM101A and LM201A,  $V_{CC\pm} = \pm 20$  V. For LM301A,  $V_{CC\pm} = \pm 15$  V.

TYPICAL CHARACTERISTICS

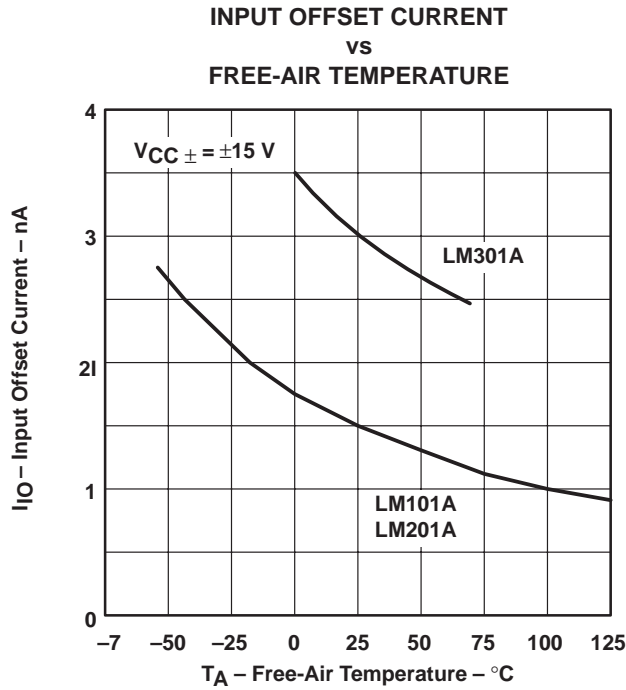

Figure 1

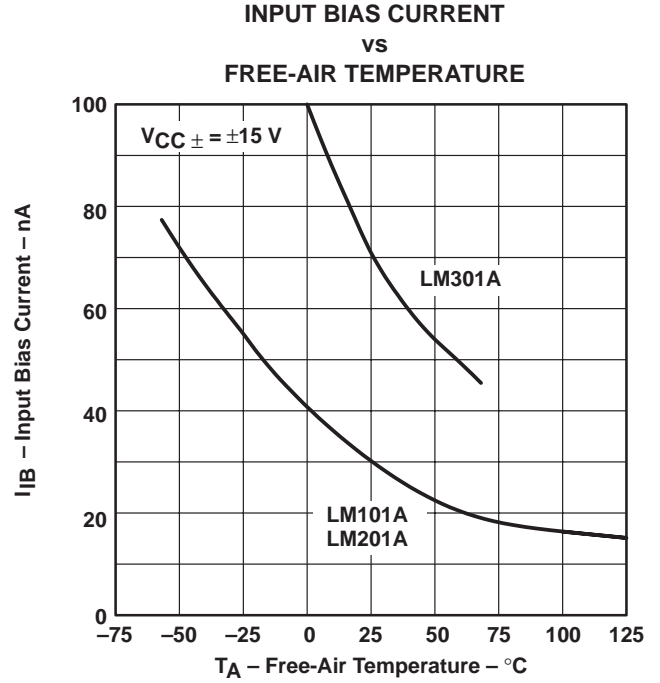

Figure 2

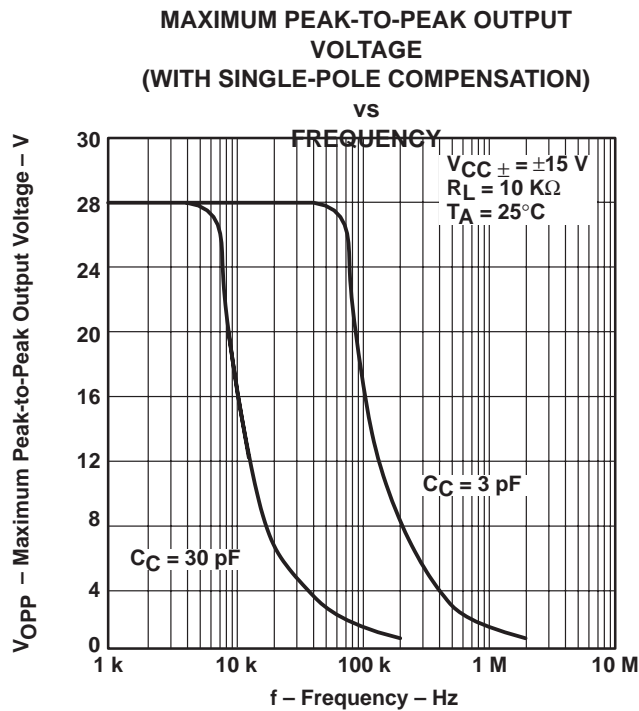

Figure 3

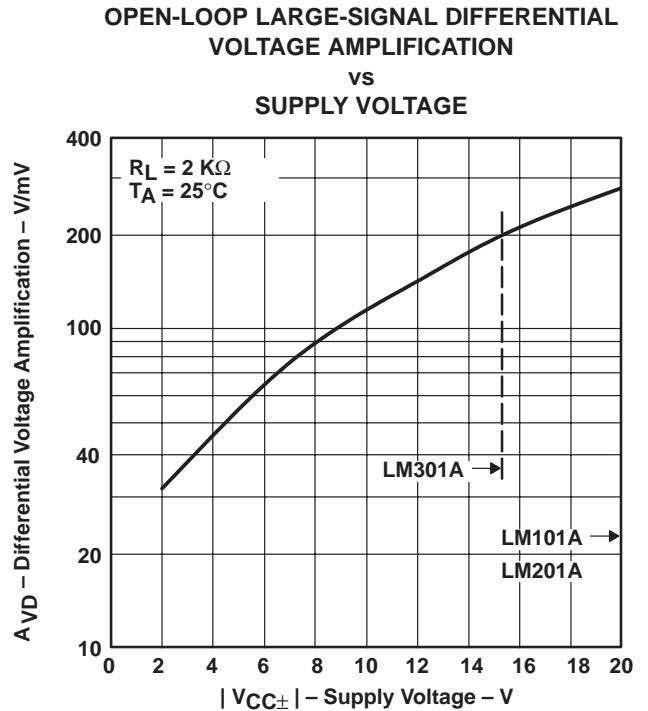

Figure 4

TYPICAL CHARACTERISTICS

OPEN-LOOP LARGE-SIGNAL DIFFERENTIAL  
VOLTAGE AMPLIFICATION  
vs  
FREQUENCY

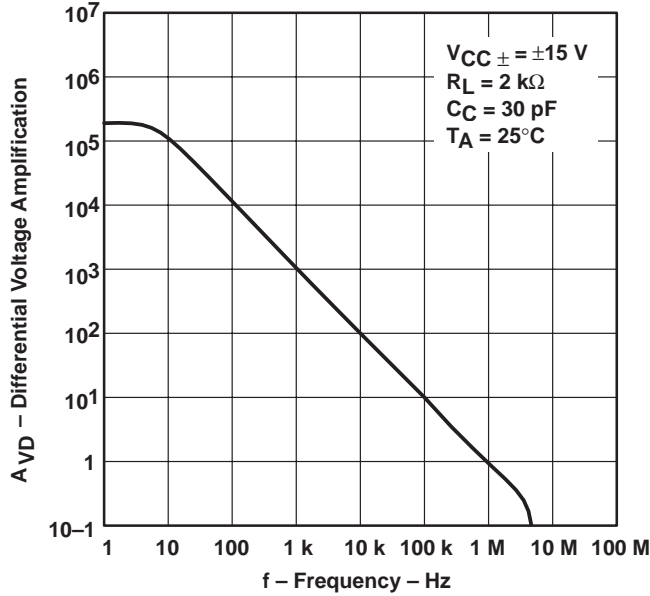

Figure 5

VOLTAGE-FOLLOWER  
LARGE-SIGNAL PULSE RESPONSE

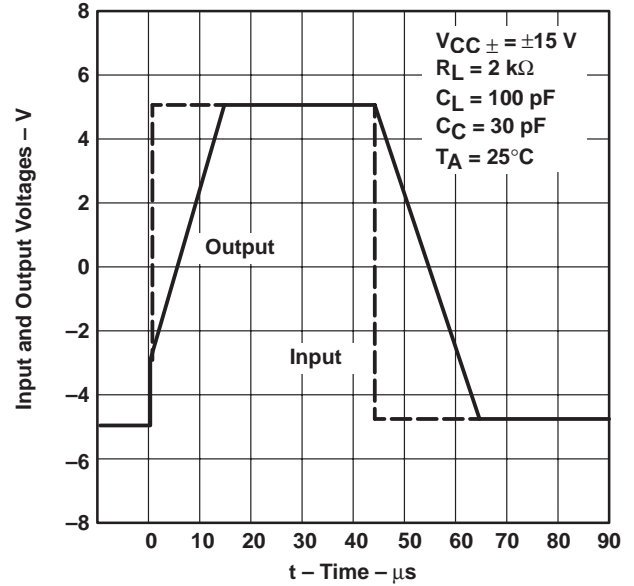
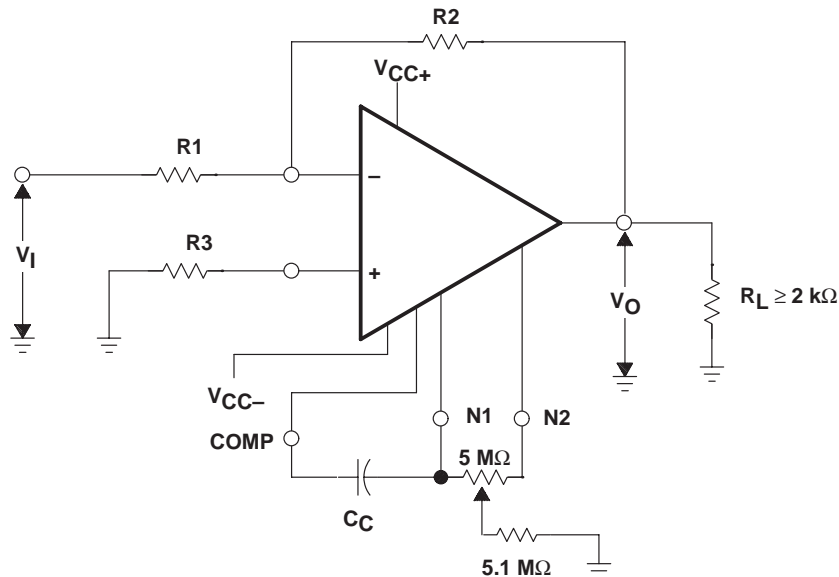

Figure 6

TYPICAL APPLICATION DATA



$$\frac{V_O}{V_I} = - \frac{R_2}{R_1}$$

$$C_C \cong \frac{R_1 \cdot 30 \text{ pF}}{R_1 + R_2}$$

$$R_3 = \frac{R_1 \cdot R_2}{R_1 + R_2}$$

Figure 7. Inverting Circuit with Adjustable Gain, Single-Pole Compensation, and Offset Adjustment

LM101A, LM201A, LM301A  
HIGH-PERFORMANCE OPERATIONAL AMPLIFIERS

---

## IMPORTANT NOTICE

Texas Instruments and its subsidiaries (TI) reserve the right to make changes to their products or to discontinue any product or service without notice, and advise customers to obtain the latest version of relevant information to verify, before placing orders, that information being relied on is current and complete. All products are sold subject to the terms and conditions of sale supplied at the time of order acknowledgement, including those pertaining to warranty, patent infringement, and limitation of liability.

TI warrants performance of its semiconductor products to the specifications applicable at the time of sale in accordance with TI's standard warranty. Testing and other quality control techniques are utilized to the extent TI deems necessary to support this warranty. Specific testing of all parameters of each device is not necessarily performed, except those mandated by government requirements.

CERTAIN APPLICATIONS USING SEMICONDUCTOR PRODUCTS MAY INVOLVE POTENTIAL RISKS OF DEATH, PERSONAL INJURY, OR SEVERE PROPERTY OR ENVIRONMENTAL DAMAGE ("CRITICAL APPLICATIONS"). TI SEMICONDUCTOR PRODUCTS ARE NOT DESIGNED, AUTHORIZED, OR WARRANTED TO BE SUITABLE FOR USE IN LIFE-SUPPORT DEVICES OR SYSTEMS OR OTHER CRITICAL APPLICATIONS. INCLUSION OF TI PRODUCTS IN SUCH APPLICATIONS IS UNDERSTOOD TO BE FULLY AT THE CUSTOMER'S RISK.

In order to minimize risks associated with the customer's applications, adequate design and operating safeguards must be provided by the customer to minimize inherent or procedural hazards.

TI assumes no liability for applications assistance or customer product design. TI does not warrant or represent that any license, either express or implied, is granted under any patent right, copyright, mask work right, or other intellectual property right of TI covering or relating to any combination, machine, or process in which such semiconductor products or services might be or are used. TI's publication of information regarding any third party's products or services does not constitute TI's approval, warranty or endorsement thereof.