

TL317

3-TERMINAL ADJUSTABLE REGULATOR

SLVS004G – APRIL 1979 – REVISED SEPTEMBER 2009

- **Output Voltage Range Adjustable From 1.2 V to 32 V When Used With an External Resistor Divider**
- **Output Current Capability of 100 mA**
- **Input Regulation Typically 0.01% Per Input-Voltage Change**
- **Output Regulation Typically 0.5%**
- **Ripple Rejection Typically 80 dB**

description/ordering information

The TL317 is an adjustable three-terminal positive-voltage regulator capable of supplying 100 mA over an output-voltage range of 1.2 V to 32 V. It is exceptionally easy to use and requires only two external resistors to set the output voltage.

In addition to higher performance than fixed regulators, this regulator offers full overload protection available only in integrated circuits. Included on the chip are current-limiting and thermal-overload protection. All overload-protection circuitry remains fully functional, even when ADJUSTMENT is disconnected. Normally, no capacitors are needed unless the device is situated far from the input filter capacitors, in which case an input bypass is needed. An optional output capacitor can be added to improve transient response. ADJUSTMENT can be bypassed to achieve very high ripple rejection, which is difficult to achieve with standard three-terminal regulators.

In addition to replacing fixed regulators, the TL317 regulator is useful in a wide variety of other applications. Since the regulator is floating and sees only the input-to-output differential voltage, supplies of several hundred volts can be regulated as long as the maximum input-to-output differential is not exceeded. Its primary application is that of a programmable output regulator, but by connecting a fixed resistor between ADJUSTMENT and OUTPUT, this device can be used as a precision current regulator. Supplies with electronic shutdown can be achieved by clamping ADJUSTMENT to ground, programming the output to 1.2 V, where most loads draw little current.

The TL317C is characterized for operation over the virtual-junction temperature range of 0°C to 125°C. The TL317 is characterized for operation over the virtual-junction temperature range of –20°C to 125°C.

**D OR PW PACKAGE
(TOP VIEW)**

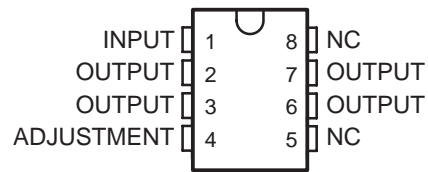

NC – No internal connection
OUTPUT terminals are all internally connected.

**PS PACKAGE
(TOP VIEW)**

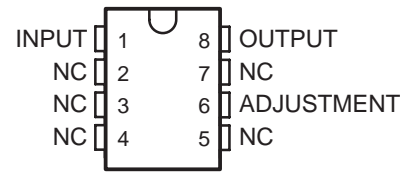

NC – No internal connection

**LP PACKAGE
(TOP VIEW)**

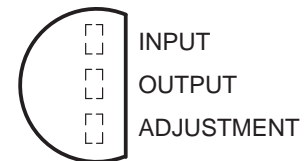

Please be aware that an important notice concerning availability, standard warranty, and use in critical applications of Texas Instruments semiconductor products and disclaimers thereto appears at the end of this data sheet.

PRODUCTION DATA information is current as of publication date. Products conform to specifications per the terms of Texas Instruments standard warranty. Production processing does not necessarily include testing of all parameters.

**TEXAS
INSTRUMENTS**

POST OFFICE BOX 655303 • DALLAS, TEXAS 75265

Copyright © 2009, Texas Instruments Incorporated

TL317

3-TERMINAL ADJUSTABLE REGULATOR

SLVS004G – APRIL 1979 – REVISED SEPTEMBER 2009

ORDERING INFORMATION

T _J	PACKAGE†		ORDERABLE PART NUMBER	TOP-SIDE MARKING
0°C to 125°C	SOIC (D)	Tube of 75	TL317CD	TL317C
		Reel of 2500	TL317CDR	
	TO-226 / TO-92 (LP)	Bulk of 1000	TL317CLP	TL317C
		Reel of 2000	TL317CLPR	
	TSSOP (PW)	Tube of 150	TL317CPW	T317
		Reel of 2000	TL317CPWR	
-20°C to 125°C	TO-226 / TO-92 (LP)	Bulk of 1000	TL317LP	TL317
	SOP (PS)	Tube of 80	TL317PS	T317
		Reel of 2000	TL317PSR	

† Package drawings, standard packing quantities, thermal data, symbolization, and PCB design guidelines are available at www.ti.com/sc/package.

TL317 3-TERMINAL ADJUSTABLE REGULATOR

SLVS004G – APRIL 1979 – REVISED SEPTEMBER 2009

schematic

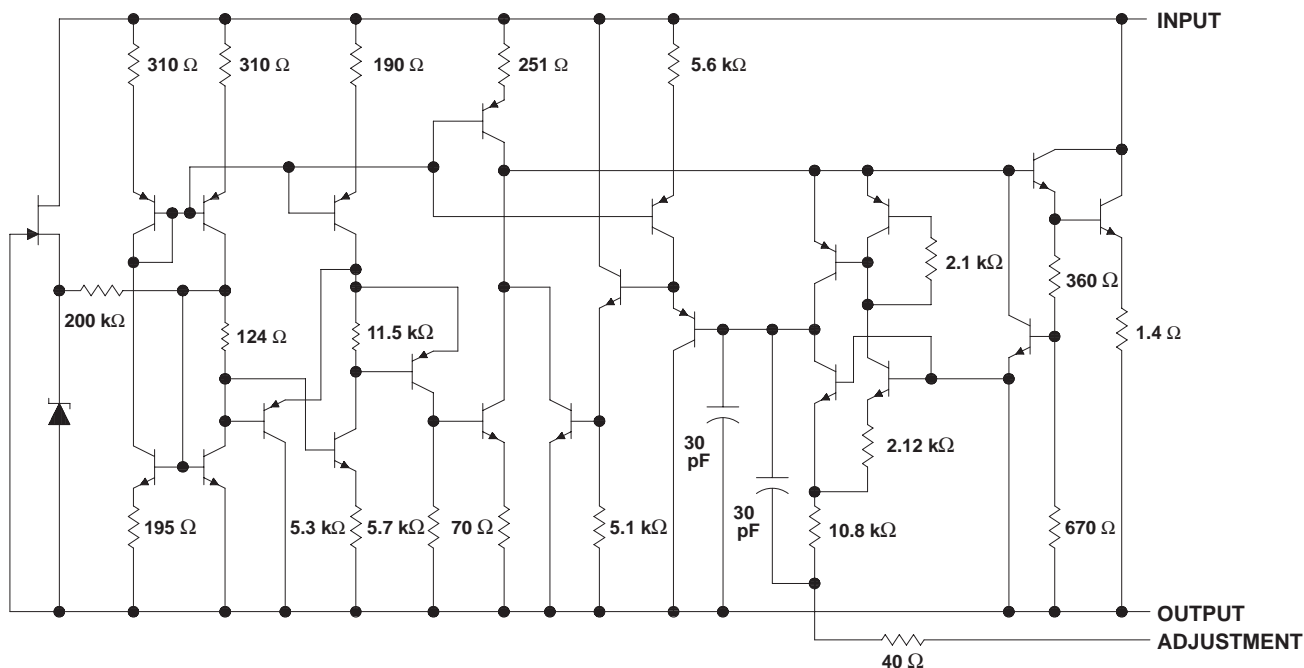

NOTE A: All component values shown are nominal.

absolute maximum ratings over operating temperature range (unless otherwise noted)†

Input-to-output differential voltage, $V_I - V_O$	35 V
Package thermal impedance, θ_{JA} (see Notes 1 and 2): D package	97°C/W
LP package	140°C/W
PS package	95°C/W
PW package	149°C/W
Operating virtual junction temperature, T_J	150°C
Storage temperature range, T_{stg}	-65°C to 150°C

† Stresses beyond those listed under “absolute maximum ratings” may cause permanent damage to the device. These are stress ratings only, and functional operation of the device at these or any other conditions beyond those indicated under “recommended operating conditions” is not implied. Exposure to absolute-maximum-rated conditions for extended periods may affect device reliability.

- NOTES: 1. Maximum power dissipation is a function of $T_J(\max)$, θ_{JA} , and T_A . The maximum allowable power dissipation at any allowable ambient temperature is $P_D = (T_J(\max) - T_A)/\theta_{JA}$. Operating at the absolute maximum T_J of 150°C can affect reliability.
2. The package thermal impedance is calculated in accordance with JESD 51-7.

recommended operating conditions

		MIN	MAX	UNIT	
$V_I - V_O$	Input-to-output voltage differential		35	V	
I_O	Output current	2.5	100	mA	
T_J	Operating virtual-junction temperature	TL317C	0	125	°C
		TL317	-20	125	°C

TL317

3-TERMINAL ADJUSTABLE REGULATOR

SLVS004G – APRIL 1979 – REVISED SEPTEMBER 2009

electrical characteristics over recommended operating virtual-junction temperature range (unless otherwise noted)

PARAMETER	TEST CONDITIONS†		TL317C			UNIT
			MIN	TYP	MAX	
Input voltage regulation (see Note 3)	$V_I - V_O = 5\text{ V to }35\text{ V}$	$T_J = 25^\circ\text{C}$	0.01	0.02		%V
		$I_O = 2.5\text{ mA to }100\text{ mA}$	0.02	0.05		
Ripple regulation	$V_O = 10\text{ V},$	$f = 120\text{ Hz}$	65			dB
	$V_O = 10\text{ V},$ 10- μF capacitor between ADJUSTMENT and ground		66	80		
Output voltage regulation	$V_I = 5\text{ V to }35\text{ V},$ $I_O = 2.5\text{ mA to }100\text{ mA},$ $T_J = 25^\circ\text{C}$	$V_O \leq 5\text{ V}$	25			mV
		$V_O \geq 5\text{ V}$	5			mV/V
	$V_I = 5\text{ V to }35\text{ V},$ $I_O = 2.5\text{ mA to }100\text{ mA}$	$V_O \leq 5\text{ V}$	50			mV
		$V_O \geq 5\text{ V}$	10			mV/V
Output voltage change with temperature	$T_J = 0^\circ\text{C to }125^\circ\text{C}$		10			mV/V
Output voltage long-term drift	After 1000 hours at $T_J = 125^\circ\text{C}$ and $V_I - V_O = 35\text{ V}$		3	10		mV/V
Output noise voltage	$f = 10\text{ Hz to }10\text{ kHz},$	$T_J = 25^\circ\text{C}$	30			$\mu\text{V/V}$
Minimum output current to maintain regulation	$V_I - V_O = 35\text{ V}$		1.5	2.5		mA
Peak output current	$V_I - V_O \leq 35\text{ V}$		100	200		mA
ADJUSTMENT current			50	100		μA
Change in ADJUSTMENT current	$V_I - V_O = 2.5\text{ V to }35\text{ V},$	$I_O = 2.5\text{ mA to }100\text{ mA}$	0.2	5		μA
Reference voltage (output to ADJUSTMENT)	$V_I - V_O = 5\text{ V to }35\text{ V},$ $P \leq \text{rated dissipation}$	$I_O = 2.5\text{ mA to }100\text{ mA},$	1.2	1.25	1.3	V

† Unless otherwise noted, these specifications apply for the following test conditions: $V_I - V_O = 5\text{ V}$ and $I_O = 40\text{ mA}$. Pulse-testing techniques must be used that maintain the junction temperature as close to the ambient temperature as possible. All characteristics are measured with a 0.1- μF capacitor across the input and a 1- μF capacitor across the output.

NOTE 3: Input voltage regulation is expressed here as the percentage change in output voltage per 1-V change at the input.



APPLICATION INFORMATION

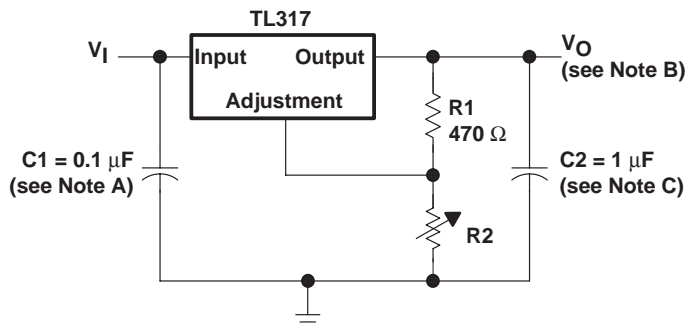

NOTES: A. Use of an input bypass capacitor is recommended if regulator is far from the filter capacitors.

B. Output voltage is calculated from the equation:

$$V_O = V_{ref} \left(1 + \frac{R_2}{R_1} \right)$$

where: V_{ref} equals the difference between OUTPUT and ADJUSTMENT voltages (≈ 1.25 V).

C. Use of an output capacitor improves transient response, but is optional.

Figure 1. Adjustable Voltage Regulator

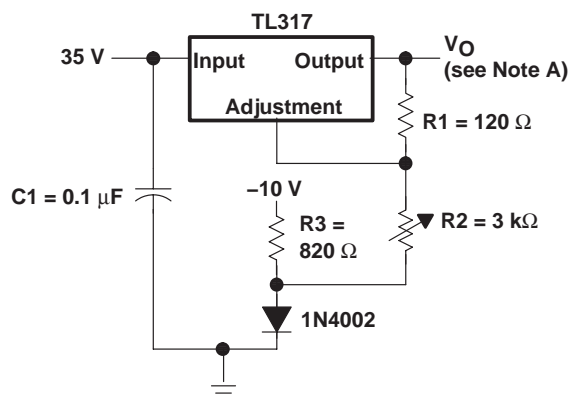

NOTE A: Output voltage is calculated from the equation:

$$V_O = V_{ref} \left(1 + \frac{R_2 + R_3}{R_1} \right) - 10 \text{ V}$$

where: V_{ref} equals the difference between OUTPUT and ADJUSTMENT voltages (≈ 1.25 V).

Figure 2. 0-V to 30-V Regulator Circuit

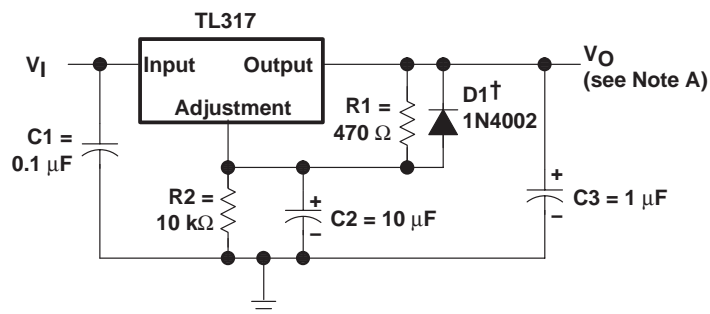

† D1 discharges C2 if output is shorted to ground.

NOTE A: Use of an output capacitor improves transient response, but is optional.

Figure 3. Regulator Circuit With Improved Ripple Rejection

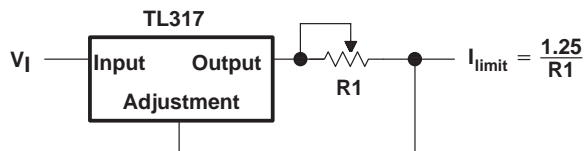

Figure 4. Precision Current-Limiter Circuit

TL317 3-TERMINAL ADJUSTABLE REGULATOR

SLVS004G – APRIL 1979 – REVISED SEPTEMBER 2009

APPLICATION INFORMATION

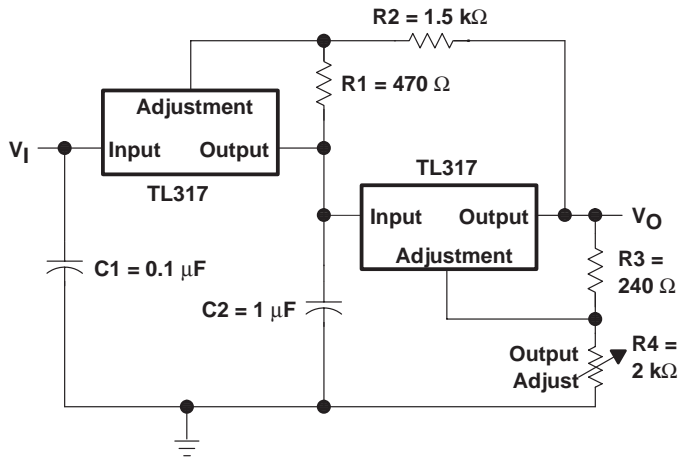

Figure 5. Tracking Preregulator Circuit

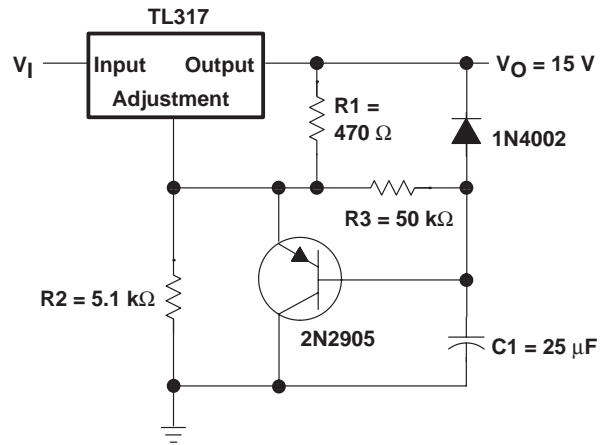

Figure 6. Slow-Turnon 15-V Regulator Circuit

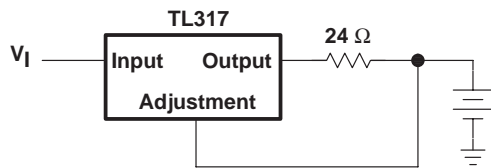

Figure 7. 50-mA Constant-Current Battery-Charger Circuit

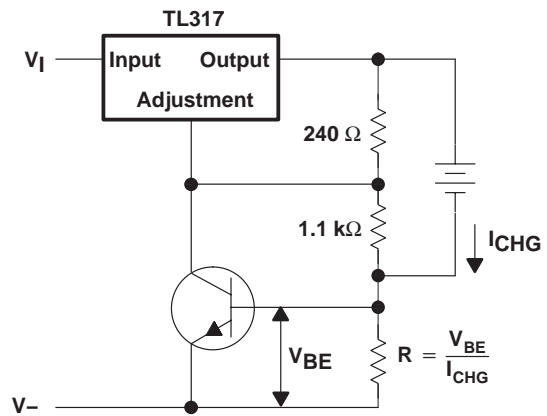
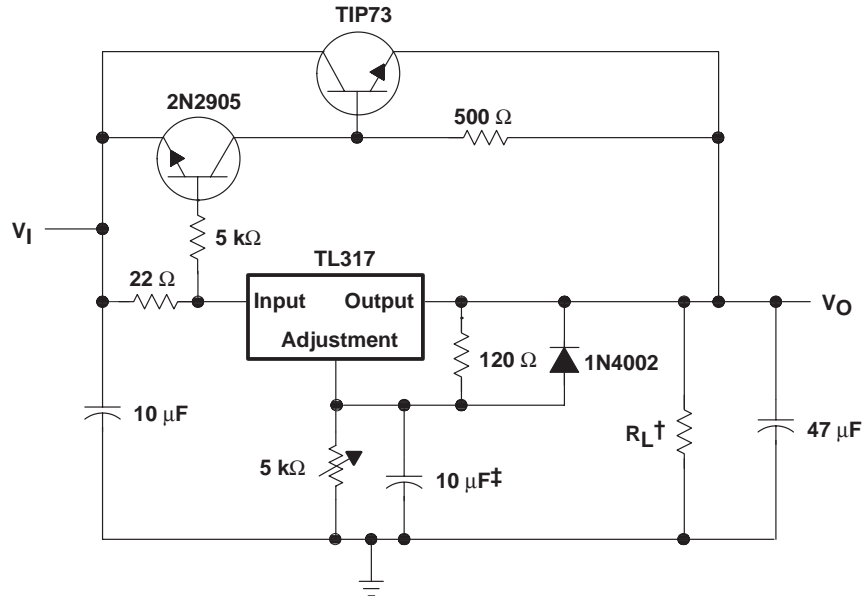

Figure 8. Current-Limited 6-V Charger

APPLICATION INFORMATION



† Minimum load current is 30 mA.
‡ Optional capacitor improves ripple rejection.

Figure 9. High-Current Adjustable Regulator

PACKAGING INFORMATION

Orderable Device	Status ⁽¹⁾	Package Type	Package Drawing	Pins	Package Qty	Eco Plan ⁽²⁾	Lead/Ball Finish	MSL Peak Temp ⁽³⁾
TL317CD	ACTIVE	SOIC	D	8	75	Green (RoHS & no Sb/Br)	CU NIPDAU	Level-1-260C-UNLIM
TL317CDE4	ACTIVE	SOIC	D	8	75	Green (RoHS & no Sb/Br)	CU NIPDAU	Level-1-260C-UNLIM
TL317CDG4	ACTIVE	SOIC	D	8	75	Green (RoHS & no Sb/Br)	CU NIPDAU	Level-1-260C-UNLIM
TL317CDR	ACTIVE	SOIC	D	8	2500	Green (RoHS & no Sb/Br)	CU NIPDAU	Level-1-260C-UNLIM
TL317CDRE4	ACTIVE	SOIC	D	8	2500	Green (RoHS & no Sb/Br)	CU NIPDAU	Level-1-260C-UNLIM
TL317CDRG4	ACTIVE	SOIC	D	8	2500	Green (RoHS & no Sb/Br)	CU NIPDAU	Level-1-260C-UNLIM
TL317CLP	ACTIVE	TO-92	LP	3	1000	Pb-Free (RoHS)	CU SN	N / A for Pkg Type
TL317CLPE3	ACTIVE	TO-92	LP	3	1000	Pb-Free (RoHS)	CU SN	N / A for Pkg Type
TL317CLPR	ACTIVE	TO-92	LP	3	2000	Pb-Free (RoHS)	CU SN	N / A for Pkg Type
TL317CLPRE3	ACTIVE	TO-92	LP	3	2000	Pb-Free (RoHS)	CU SN	N / A for Pkg Type
TL317CPW	ACTIVE	TSSOP	PW	8	150	Green (RoHS & no Sb/Br)	CU NIPDAU	Level-1-260C-UNLIM
TL317CPWE4	ACTIVE	TSSOP	PW	8	150	Green (RoHS & no Sb/Br)	CU NIPDAU	Level-1-260C-UNLIM
TL317CPWG4	ACTIVE	TSSOP	PW	8	150	Green (RoHS & no Sb/Br)	CU NIPDAU	Level-1-260C-UNLIM
TL317CPWR	ACTIVE	TSSOP	PW	8	2000	Green (RoHS & no Sb/Br)	CU NIPDAU	Level-1-260C-UNLIM
TL317CPWRE4	ACTIVE	TSSOP	PW	8	2000	Green (RoHS & no Sb/Br)	CU NIPDAU	Level-1-260C-UNLIM
TL317CPWRG4	ACTIVE	TSSOP	PW	8	2000	Green (RoHS & no Sb/Br)	CU NIPDAU	Level-1-260C-UNLIM
TL317PS	ACTIVE	SO	PS	8	80	Green (RoHS & no Sb/Br)	CU NIPDAU	Level-1-260C-UNLIM
TL317PSE4	ACTIVE	SO	PS	8	80	Green (RoHS & no Sb/Br)	CU NIPDAU	Level-1-260C-UNLIM
TL317PSG4	ACTIVE	SO	PS	8	80	Green (RoHS & no Sb/Br)	CU NIPDAU	Level-1-260C-UNLIM
TL317PSR	ACTIVE	SO	PS	8	2000	Green (RoHS & no Sb/Br)	CU NIPDAU	Level-1-260C-UNLIM
TL317PSRE4	ACTIVE	SO	PS	8	2000	Green (RoHS & no Sb/Br)	CU NIPDAU	Level-1-260C-UNLIM
TL317PSRG4	ACTIVE	SO	PS	8	2000	Green (RoHS & no Sb/Br)	CU NIPDAU	Level-1-260C-UNLIM

⁽¹⁾ The marketing status values are defined as follows:

ACTIVE: Product device recommended for new designs.

LIFEBUY: TI has announced that the device will be discontinued, and a lifetime-buy period is in effect.

NRND: Not recommended for new designs. Device is in production to support existing customers, but TI does not recommend using this part in a new design.

PREVIEW: Device has been announced but is not in production. Samples may or may not be available.

OBSOLETE: TI has discontinued the production of the device.

⁽²⁾ Eco Plan - The planned eco-friendly classification: Pb-Free (RoHS), Pb-Free (RoHS Exempt), or Green (RoHS & no Sb/Br) - please check <http://www.ti.com/productcontent> for the latest availability information and additional product content details.

TBD: The Pb-Free/Green conversion plan has not been defined.

Pb-Free (RoHS): TI's terms "Lead-Free" or "Pb-Free" mean semiconductor products that are compatible with the current RoHS requirements for all 6 substances, including the requirement that lead not exceed 0.1% by weight in homogeneous materials. Where designed to be soldered at high temperatures, TI Pb-Free products are suitable for use in specified lead-free processes.

Pb-Free (RoHS Exempt): This component has a RoHS exemption for either 1) lead-based flip-chip solder bumps used between the die and package, or 2) lead-based die adhesive used between the die and leadframe. The component is otherwise considered Pb-Free (RoHS compatible) as defined above.

Green (RoHS & no Sb/Br): TI defines "Green" to mean Pb-Free (RoHS compatible), and free of Bromine (Br) and Antimony (Sb) based flame retardants (Br or Sb do not exceed 0.1% by weight in homogeneous material)

⁽³⁾ MSL, Peak Temp. -- The Moisture Sensitivity Level rating according to the JEDEC industry standard classifications, and peak solder temperature.

Important Information and Disclaimer:The information provided on this page represents TI's knowledge and belief as of the date that it is provided. TI bases its knowledge and belief on information provided by third parties, and makes no representation or warranty as to the accuracy of such information. Efforts are underway to better integrate information from third parties. TI has taken and continues to take reasonable steps to provide representative and accurate information but may not have conducted destructive testing or chemical analysis on incoming materials and chemicals. TI and TI suppliers consider certain information to be proprietary, and thus CAS numbers and other limited information may not be available for release.

In no event shall TI's liability arising out of such information exceed the total purchase price of the TI part(s) at issue in this document sold by TI to Customer on an annual basis.

TAPE AND REEL INFORMATION

QUADRANT ASSIGNMENTS FOR PIN 1 ORIENTATION IN TAPE

*All dimensions are nominal

Device	Package Type	Package Drawing	Pins	SPQ	Reel Diameter (mm)	Reel Width W1 (mm)	A0 (mm)	B0 (mm)	K0 (mm)	P1 (mm)	W (mm)	Pin1 Quadrant
TL317CDR	SOIC	D	8	2500	330.0	12.4	6.4	5.2	2.1	8.0	12.0	Q1
TL317CPWR	TSSOP	PW	8	2000	330.0	12.4	7.0	3.6	1.6	8.0	12.0	Q1
TL317PSR	SO	PS	8	2000	330.0	16.4	8.2	6.6	2.5	12.0	16.0	Q1

TAPE AND REEL BOX DIMENSIONS

*All dimensions are nominal

Device	Package Type	Package Drawing	Pins	SPQ	Length (mm)	Width (mm)	Height (mm)
TL317CDR	SOIC	D	8	2500	340.5	338.1	20.6
TL317CPWR	TSSOP	PW	8	2000	346.0	346.0	29.0
TL317PSR	SO	PS	8	2000	346.0	346.0	33.0

PW (R-PDSO-G**)

PLASTIC SMALL-OUTLINE PACKAGE

14 PINS SHOWN



4040064/F 01/97

- NOTES: A. All linear dimensions are in millimeters.
 B. This drawing is subject to change without notice.
 C. Body dimensions do not include mold flash or protrusion not to exceed 0,15.
 D. Falls within JEDEC MO-153

MECHANICAL DATA

PS (R-PDSO-G8)

PLASTIC SMALL-OUTLINE PACKAGE

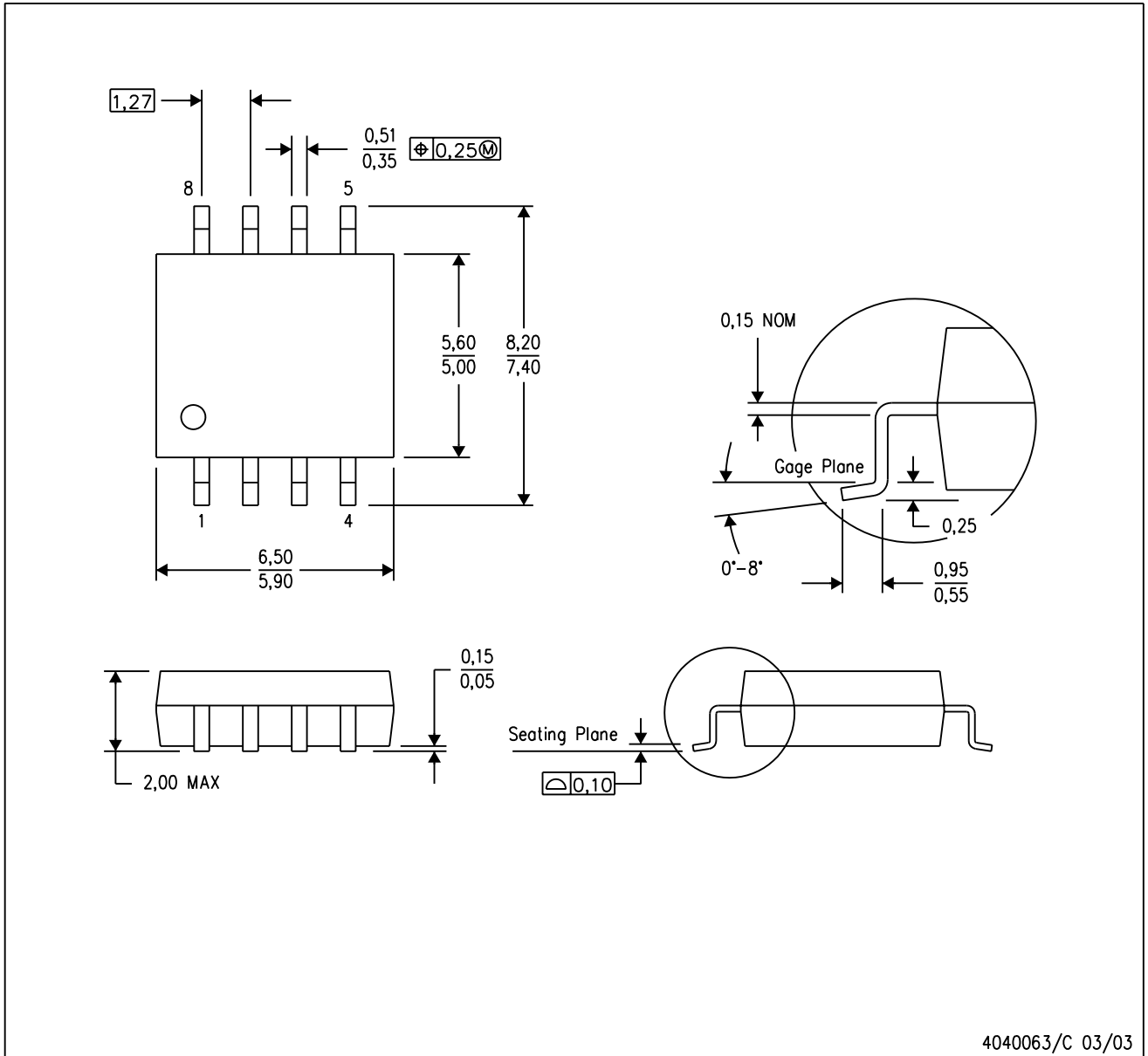

- NOTES:
- A. All linear dimensions are in millimeters.
 - B. This drawing is subject to change without notice.
 - C. Body dimensions do not include mold flash or protrusion, not to exceed 0,15.

D (R-PDSO-G8)

PLASTIC SMALL-OUTLINE PACKAGE

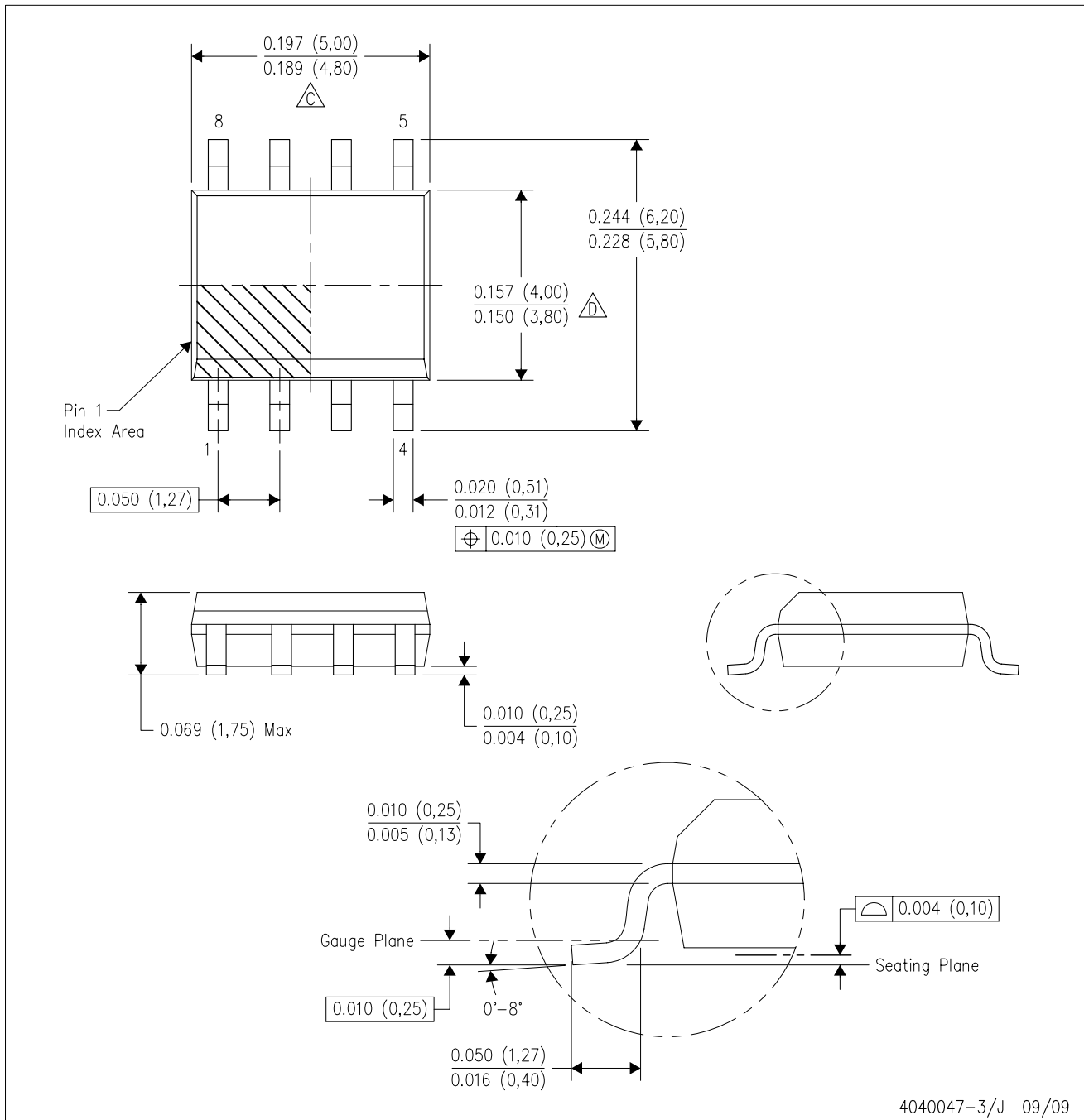

- NOTES:
- A. All linear dimensions are in inches (millimeters).
 - B. This drawing is subject to change without notice.
 - $\triangle C$ Body length does not include mold flash, protrusions, or gate burrs. Mold flash, protrusions, or gate burrs shall not exceed .006 (0,15) per end.
 - $\triangle D$ Body width does not include interlead flash. Interlead flash shall not exceed .017 (0,43) per side.
 - E. Reference JEDEC MS-012 variation AA.

LP (O-PBCY-W3)

PLASTIC CYLINDRICAL PACKAGE

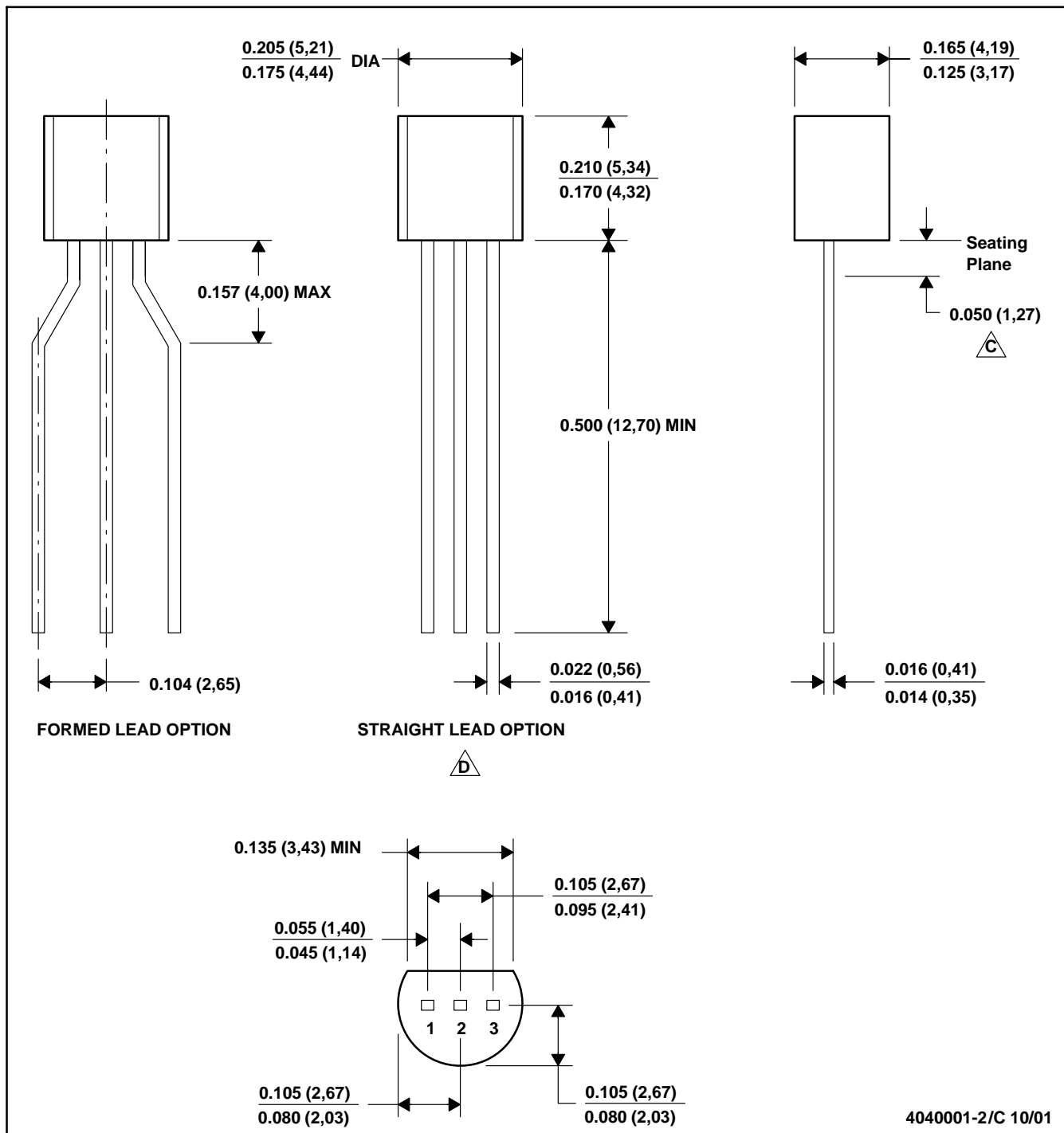

- NOTES: A. All linear dimensions are in inches (millimeters).
 B. This drawing is subject to change without notice.
 C. Lead dimensions are not controlled within this area
 D. Falls within JEDEC TO -226 Variation AA (TO-226 replaces TO-92)
 E. Shipping Method:
 Straight lead option available in bulk pack only.
 Formed lead option available in tape & reel or ammo pack.

MECHANICAL DATA

MSOT002A – OCTOBER 1994 – REVISED NOVEMBER 2001

LP (O-PBCY-W3)

PLASTIC CYLINDRICAL PACKAGE

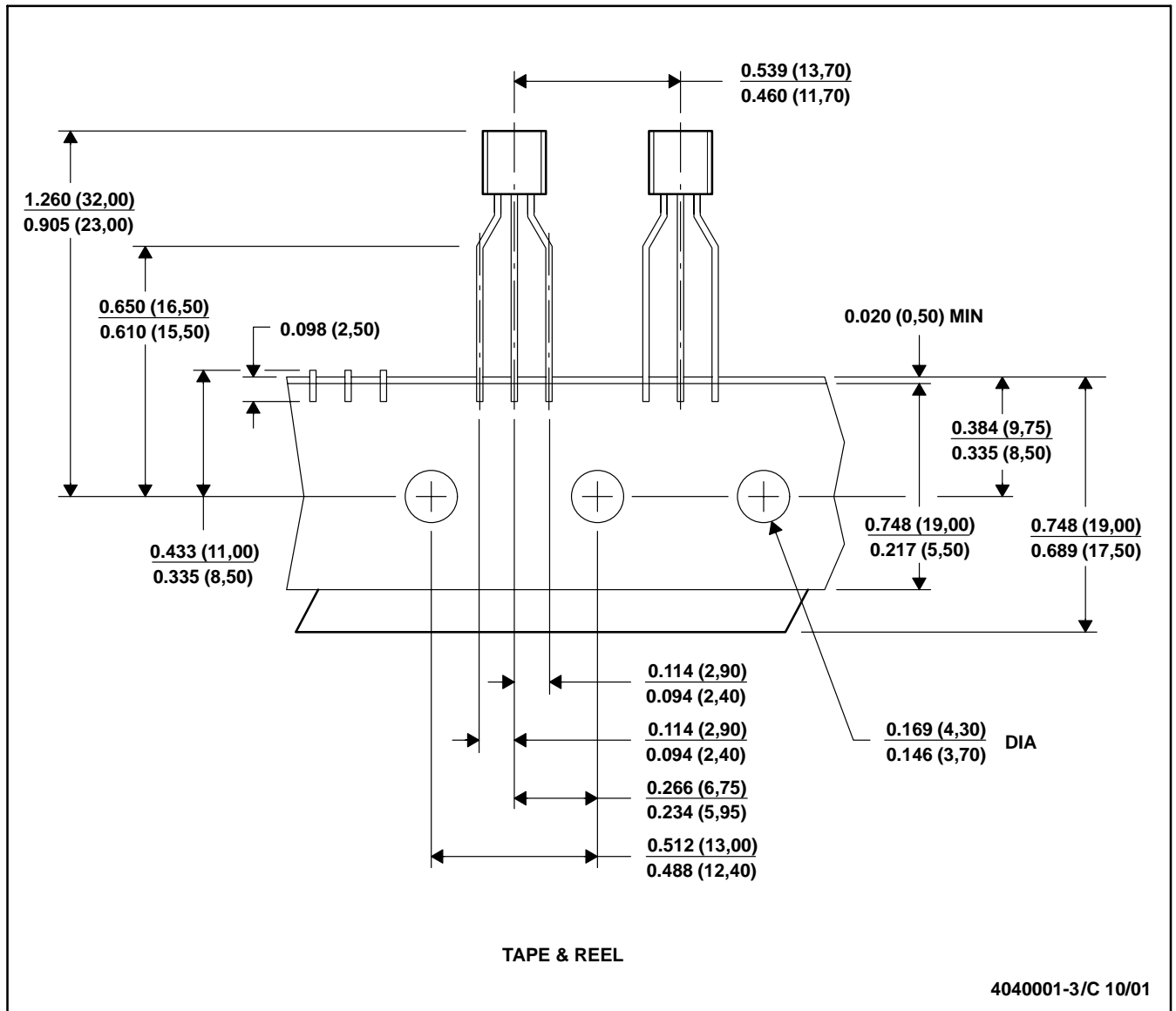

- NOTES: A. All linear dimensions are in inches (millimeters).
 B. This drawing is subject to change without notice.
 C. Tape and Reel information for the Format Lead Option package.

IMPORTANT NOTICE

Texas Instruments Incorporated and its subsidiaries (TI) reserve the right to make corrections, modifications, enhancements, improvements, and other changes to its products and services at any time and to discontinue any product or service without notice. Customers should obtain the latest relevant information before placing orders and should verify that such information is current and complete. All products are sold subject to TI's terms and conditions of sale supplied at the time of order acknowledgment.

TI warrants performance of its hardware products to the specifications applicable at the time of sale in accordance with TI's standard warranty. Testing and other quality control techniques are used to the extent TI deems necessary to support this warranty. Except where mandated by government requirements, testing of all parameters of each product is not necessarily performed.

TI assumes no liability for applications assistance or customer product design. Customers are responsible for their products and applications using TI components. To minimize the risks associated with customer products and applications, customers should provide adequate design and operating safeguards.

TI does not warrant or represent that any license, either express or implied, is granted under any TI patent right, copyright, mask work right, or other TI intellectual property right relating to any combination, machine, or process in which TI products or services are used. Information published by TI regarding third-party products or services does not constitute a license from TI to use such products or services or a warranty or endorsement thereof. Use of such information may require a license from a third party under the patents or other intellectual property of the third party, or a license from TI under the patents or other intellectual property of TI.

Reproduction of TI information in TI data books or data sheets is permissible only if reproduction is without alteration and is accompanied by all associated warranties, conditions, limitations, and notices. Reproduction of this information with alteration is an unfair and deceptive business practice. TI is not responsible or liable for such altered documentation. Information of third parties may be subject to additional restrictions.

Resale of TI products or services with statements different from or beyond the parameters stated by TI for that product or service voids all express and any implied warranties for the associated TI product or service and is an unfair and deceptive business practice. TI is not responsible or liable for any such statements.

TI products are not authorized for use in safety-critical applications (such as life support) where a failure of the TI product would reasonably be expected to cause severe personal injury or death, unless officers of the parties have executed an agreement specifically governing such use. Buyers represent that they have all necessary expertise in the safety and regulatory ramifications of their applications, and acknowledge and agree that they are solely responsible for all legal, regulatory and safety-related requirements concerning their products and any use of TI products in such safety-critical applications, notwithstanding any applications-related information or support that may be provided by TI. Further, Buyers must fully indemnify TI and its representatives against any damages arising out of the use of TI products in such safety-critical applications.

TI products are neither designed nor intended for use in military/aerospace applications or environments unless the TI products are specifically designated by TI as military-grade or "enhanced plastic." Only products designated by TI as military-grade meet military specifications. Buyers acknowledge and agree that any such use of TI products which TI has not designated as military-grade is solely at the Buyer's risk, and that they are solely responsible for compliance with all legal and regulatory requirements in connection with such use.

TI products are neither designed nor intended for use in automotive applications or environments unless the specific TI products are designated by TI as compliant with ISO/TS 16949 requirements. Buyers acknowledge and agree that, if they use any non-designated products in automotive applications, TI will not be responsible for any failure to meet such requirements.

Following are URLs where you can obtain information on other Texas Instruments products and application solutions:

Products

Amplifiers	amplifier.ti.com
Data Converters	dataconverter.ti.com
DLP® Products	www.dlp.com
DSP	dsp.ti.com
Clocks and Timers	www.ti.com/clocks
Interface	interface.ti.com
Logic	logic.ti.com
Power Mgmt	power.ti.com
Microcontrollers	microcontroller.ti.com
RFID	www.ti-rfid.com
RF/IF and ZigBee® Solutions	www.ti.com/lprf

Applications

Audio	www.ti.com/audio
Automotive	www.ti.com/automotive
Broadband	www.ti.com/broadband
Digital Control	www.ti.com/digitalcontrol
Medical	www.ti.com/medical
Military	www.ti.com/military
Optical Networking	www.ti.com/opticalnetwork
Security	www.ti.com/security
Telephony	www.ti.com/telephony
Video & Imaging	www.ti.com/video
Wireless	www.ti.com/wireless

Mailing Address: Texas Instruments, Post Office Box 655303, Dallas, Texas 75265
Copyright © 2009, Texas Instruments Incorporated