

AC / DC converter

BP5035 / BP5035-5

The BP5035 and BP5035-5 are an AC / DC converters which can be used to supply DC output from a commercial power supply (100V AC). Using these modules enables simple, easy drive of microcomputers, DC motors, heaters, LEDs, and many other electronic components without using a transformer. They also allow set PCBs to be kept compact and lightweight, with extremely few attachments.

●Applications

Power supply circuits for vacuum cleaners, washing machines, refrigerators, electric carpets, electric rice cookers and crock pots, irons, cordless telephones, air purifiers, humidifiers, dehumidifiers, illumination devices and other small household appliances, as well as power supply circuits for gas, fire and smoke alarms, DC motors, sensors, and other similar devices

●Features

- 1) Elimination of a transformer enables compact, lightweight power supply boards.
- 2) Wide input voltage range. (80 to 120Vrms for AC voltage conversion)
- 3) DC power supplies can be easily configured, with few attachments.
- 4) The output current is large, at 200mA.
- 5) +COMMON of -12V (BP5035) / -5V (BP5035-5) outputs are provided. These are ideal for TRIAC drive for AC control.
- 6) Because no transformer is used, the power supply board is less vulnerable to splitting or cracking from impact or shock.
- 7) Allow easy assemblage of components.

●List of the BP5035 series

	BP5035	BP5035-5	Unit
Power supply voltage	-113~-170	-113~-170	V
Output voltage	-12	-5	V
Output current	200	200	mA

●Absolute maximum ratings (Ta=25°C)

Parameter	Symbol	Limits		Unit
		BP5035	BP5035-5	
Power supply voltage	V _{IN}	-170	-170	V
Output current	I _o	200	200	mA
Operating temperature range	T _{opr}	-25~+80	-25~+80	°C
Storage temperature range	T _{stg}	-25~+80	-25~+80	°C

Power Module

●Recommended operating conditions (Ta=25°C)

Parameter	Symbol	Min.	Typ.	Max.	Unit
Power supply voltage	V _{IN}	-113	-141	-170	V (DC)

●Electrical characteristics (Unless otherwise noted, Ta=25°C)

BP5035

Parameter	Symbol	Min.	Typ.	Max.	Unit	Conditions
Input voltage	V _{IN}	-113	-141	-170	V	DC
Output voltage	V _O	-11	-12	-13	V	V _{IN} =-141V, I _O =-200mA
Output current	I _O	0	-	200	mA	V _{IN} =-141V *1
Line regulation	V _r	-	0.04	0.15	V	V _{IN} =-113~-170V, I _O =-200mA
Load regulation	V _l	-	0.05	0.15	V	I _O =0~-200mA, V _{IN} =-141V
Output ripple voltage	V _p	-	0.05	0.15	V _{PP}	V _{IN} =-141V, I _O =-200mA *2
Conversion efficiency	η	60	74	-	%	V _{IN} =-141V, I _O =-200mA

BP5035-5

Parameter	Symbol	Min.	Typ.	Max.	Unit	Conditions
Input voltage	V _{IN}	-113	-141	-170	V	DC
Output voltage	V _O	-4.7	-5.0	-5.3	V	V _{IN} =-141V, I _O =-100mA
Output current	I _O	0	-	200	mA	V _{IN} =-141V *1
Line regulation	V _r	-	0.04	0.15	V	V _{IN} =-113~-170V, I _O =-100mA
Load regulation	V _l	-	0.05	0.15	V	I _O =0~-100mA, V _{IN} =-141V
Output ripple voltage	V _p	-	0.07	0.15	V _{PP}	V _{IN} =-141V, I _O =-100mA *2
Conversion efficiency	η	50	60	-	%	V _{IN} =-141V, I _O =-200mA

*1 Maximum output varies depending on ambient temperature ; please refer to derating curve.

*2 Spike noise is not included in output ripple voltage.

●Pin descriptions

Pin No.	Pin name
1	V _{OUT}
3	COIL
5	COIL
7	COMMON
10	V _{IN}

Pins 2,4,6,8,9 are removed.

Power Module

● Measurement circuit

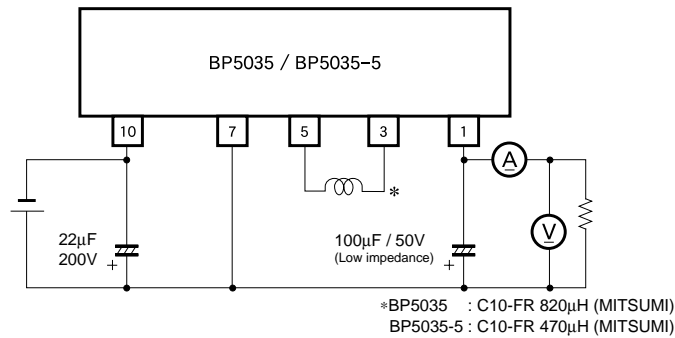

Fig.1

● Application example

Basic power supply circuit

Half wave rectifier circuit

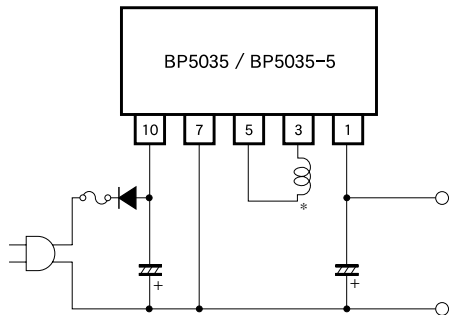

Fig.2

Full wave rectifier circuit

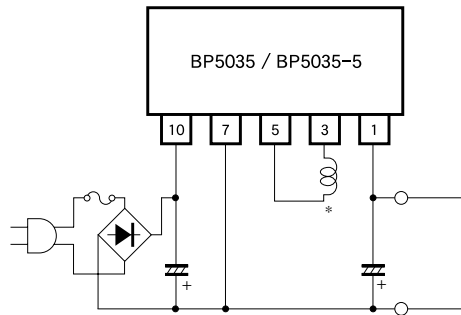

Fig.3

*BP5035 : C10-FR 820µH (MITSUMI)
BP5035-5 : C10-FR 470µH (MITSUMI)

Example showing BP5035 used in washing machine

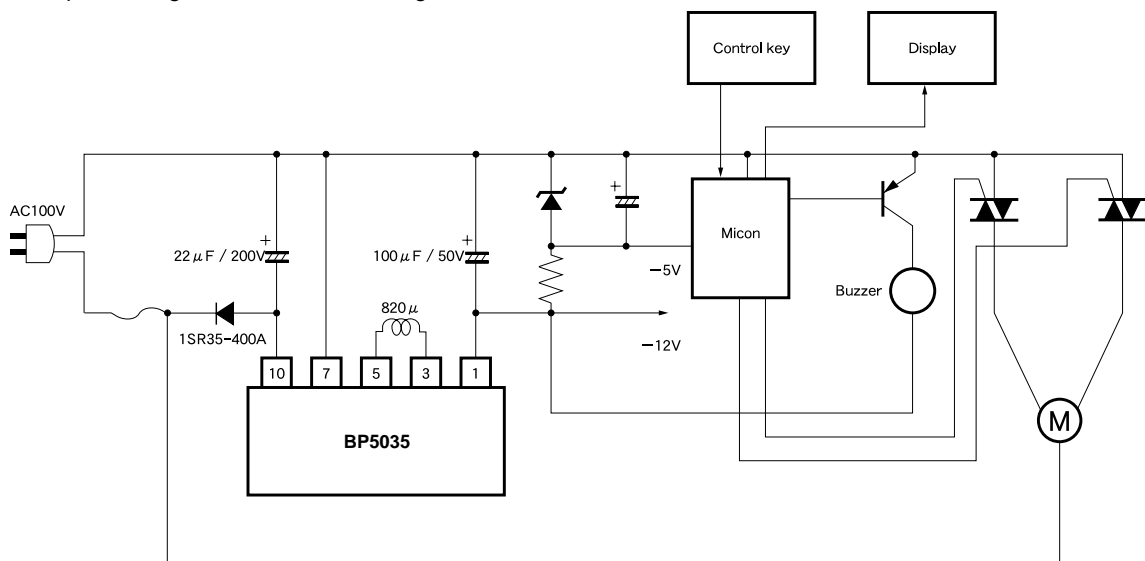

Fig.4

Power Module

●Selecting attachments

(1) Diodes

The rectifying diodes used should fulfill the following conditions.

In the absolute maximum ratings, the reverse peak voltage should be 400V or higher, the average rectifying current should be 0.5A or higher, and the forward peak surge current should be 20A or higher.

(2) Smoothing capacitor for input pin

A capacitor with a larger capacitance produces a more stable output voltage, but increases the rush current when the power supply is turned on. The capacitor should have a withstand voltage of at least 200V. Make sure a capacitor of 22 μ F or higher is used for half wave rectification, and 6.8 μ F or higher for full wave rectification.

(3) Smoothing capacitor for output pin

This capacitor should have a low ESR. The low-impedance capacitors designed for switching power supplies are especially suitable. The ESR of the capacitor affects the output ripple voltage.

●Operation notes

(1) The output current needs to be reduced as the ambient temperature rises.

(2) Lead pins should be securely soldered. If COMMON pins are not securely connected, or pins which are connected internally but which are not used are connected to other pins, irregular voltages could be produced, causing breakdowns and damage.

(3) Over current and shorted circuit.

The over current limit is a drooping model. At 25°C, if over current which exceeds the absolute maximum ratings is produced intermittently, or is produced continuously for a total of one minute or longer, these products are vulnerable to damage. If there is any danger of the load being shorted or over current being produced, always use a protective device such as a fuse.

(4) Avoid subjecting these products to strong impact.

(5) Regulations on Electrical Appliances

As stand-alone products, they are not subject to regulation governing electrical appliances. Please be aware, therefore, that applications must be submitted for sets and not for individual products.

(6) Insulation

These products are not insulated on the primary and secondary sides, and there is a danger of electrical shock if they are touched.

(7) Connections with other devices

Device using these products should not be connected to other devices. If connected, insulation should be provided.

(8) External I / O capacitors should be positioned as close as possible to pins, and coils should be positioned as follows.

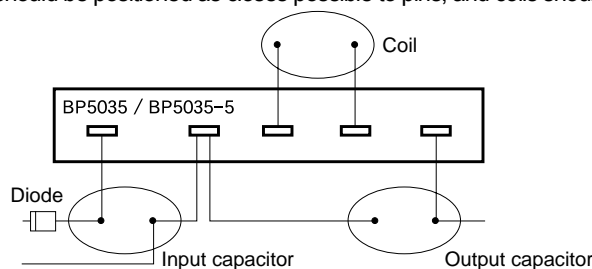

Power Module

●Electrical characteristic curves

BP5035

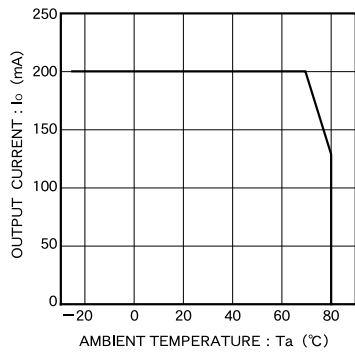

Fig.5 Derating curve

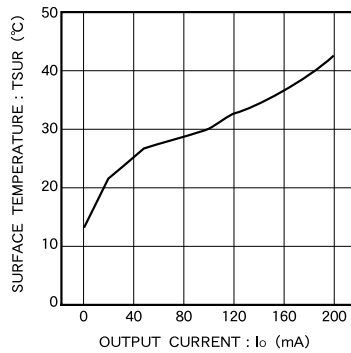

Fig.6 Surface temperature rise

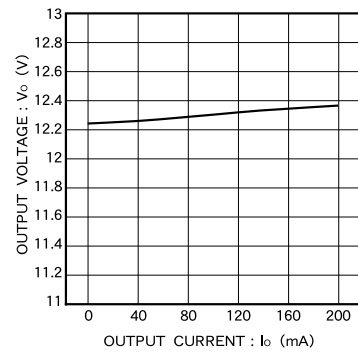

Fig.7 Output characteristic

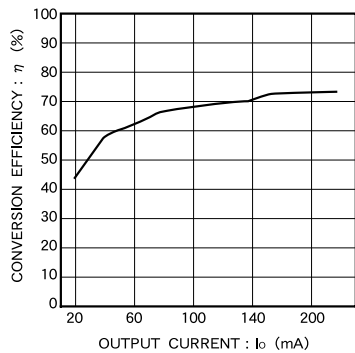

Fig.8 Conversion efficiency

BP5035-5

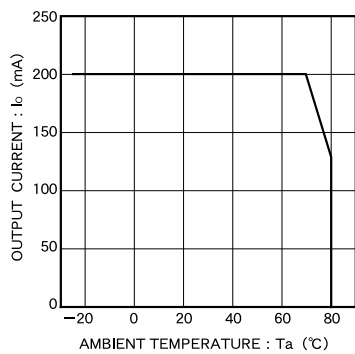

Fig.9 Derating curve

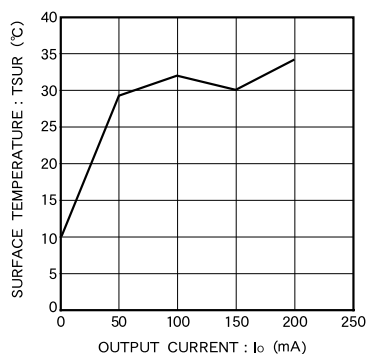

Fig.10 Surface temperature rise

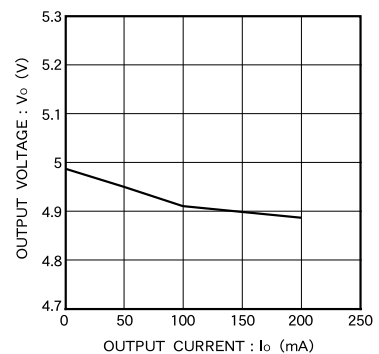

Fig.11 Output characteristic

Power Module

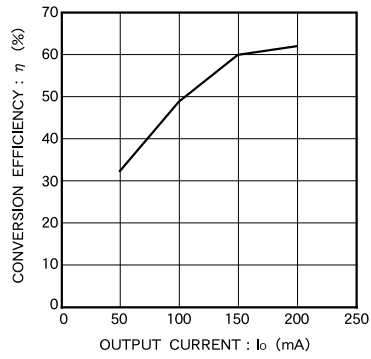
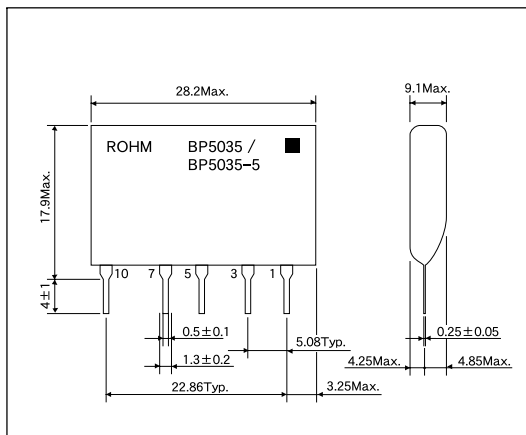

Fig.12 Conversion efficiency

●External dimensions (Units: mm)



Notes

- No technical content pages of this document may be reproduced in any form or transmitted by any means without prior permission of ROHM CO.,LTD.
- The contents described herein are subject to change without notice. The specifications for the product described in this document are for reference only. Upon actual use, therefore, please request that specifications to be separately delivered.
- Application circuit diagrams and circuit constants contained herein are shown as examples of standard use and operation. Please pay careful attention to the peripheral conditions when designing circuits and deciding upon circuit constants in the set.
- Any data, including, but not limited to application circuit diagrams information, described herein are intended only as illustrations of such devices and not as the specifications for such devices. ROHM CO.,LTD. disclaims any warranty that any use of such devices shall be free from infringement of any third party's intellectual property rights or other proprietary rights, and further, assumes no liability of whatsoever nature in the event of any such infringement, or arising from or connected with or related to the use of such devices.
- Upon the sale of any such devices, other than for buyer's right to use such devices itself, resell or otherwise dispose of the same, no express or implied right or license to practice or commercially exploit any intellectual property rights or other proprietary rights owned or controlled by
- ROHM CO., LTD. is granted to any such buyer.
- Products listed in this document use silicon as a basic material.
Products listed in this document are no antiradiation design.

The products listed in this document are designed to be used with ordinary electronic equipment or devices (such as audio visual equipment, office-automation equipment, communications devices, electrical appliances and electronic toys).

Should you intend to use these products with equipment or devices which require an extremely high level of reliability and the malfunction of which would directly endanger human life (such as medical instruments, transportation equipment, aerospace machinery, nuclear-reactor controllers, fuel controllers and other safety devices), please be sure to consult with our sales representative in advance.

About Export Control Order in Japan

Products described herein are the objects of controlled goods in Annex 1 (Item 16) of Export Trade Control Order in Japan.

In case of export from Japan, please confirm if it applies to "objective" criteria or an "informed" (by MITI clause) on the basis of "catch all controls for Non-Proliferation of Weapons of Mass Destruction.